

# Sourcing & Supply Chain Strategy

## MSc Fashion Buying & Merchandising Management



# Contents

1.Original Proposal	Pg 1
2.Introduction	Pg 2
3.Brand Overview	Pg 3
4.Consumers	Pg 7
5.Competitor Analysis	Pg 6
6.Trend Analysis	Pg 16
7.Final Range Plan	Pg 19
8.Pricing Architecture	Pg 21
9.Sourcing Strategy	Pg 23
10.Technical Specification	Pg 27
11.Product Costing	Pg 40
12.Nike’s DTC and Wholesale	Pg 45
13.Projected Sales and Promotional Plan	Pg 47
14.Critical Path	Pg 54
15.Sustainability Initiatives	Pg 55
16.Conclusion	Pg 57
17. Costing Resources	Pg 58
18. References	Pg 59
19.Image References	Pg 62
20.Bibliography	Pg 63

# Original Proposal

The initial pitch was a utilitarian hoodie aiding anxiety, executed in partnership with Nike. The hoodie is constructed with the concept revolving around the 5 senses. Despite the hoodie being the main component, the range line comprises of several other goods that only partially include the various components. This idea can assist Nike improve its ESG model, as well as culture improvement in the workplace and with employees. Bearing in mind its focus on young people and the expanding athleisure industry, this campaign has a high probability of generating revenue as well.



Fig 1 (Created on Illustrator)

# Anxiety UK

## Introduction

In accordance with the original proposal, the concept is carried out with a few modest modifications, such as partnerships and a narrow target market, considering sales and profitability.

The Mental Health Foundation estimates that one in five women suffer from a common mental health issue like depression or anxiety. And anxiety is proved to be prevalent (Bahrami, Yousefi, 2011) and more often in women when compared to men. Although each person's anxiety has a unique origin, it is shown that biological gender differences account for these variations (Griffiths, 2021).

To address this, the capsule collection is created exclusively for women and includes the attributes mentioned in the pitch.

Given the lack of knowledge on mental health, the utilitarian hoodie containing the six components to assist cope with anxiety may not be strategically marketable.

In order to better serve individuals who, suffer from anxiety disorders, this campaign is run in collaboration with Anxiety UK, a UK national registered charity founded in 1970, providing services including counseling, support groups, Art for Anxiety Relief (AFAR), and management courses, it is the largest national user-led charity addressing anxiety (Anxiety UK, 2023).

In collaboration with this organization, the utilitarian hoodie is supplied to them to aid in the treatment of anxiety, and a display is set up in each Nike location across the England to educate shoppers.

As for the rest of the products in the range, sold to the consumers, is designed with accordance to trend, style along with the traits that is clinically proven in assisting a healthy feel-good mind.

# Brand Overview

The largest and most lucrative manufacturer of sportswear in the world, Nike is best recognized for its footwear, gear, and clothing. Nike manufactures and markets a variety of athletic and sporting goods, including footwear, apparel, equipment, and services. Nike generates money supplying to wholesale clients who sell Nike brands to retailers across the world.

It markets its clothing under the brand name Nike as well as through its Jordan and Converse subsidiaries. (Tunney, 2022). With more than 6.6 million searches on average each month, Nike tops the list of the most popular athletic companies in the US (Lockwood, 2023).



# ***But why is Nike the most popular ?***

## **Brand strategy**

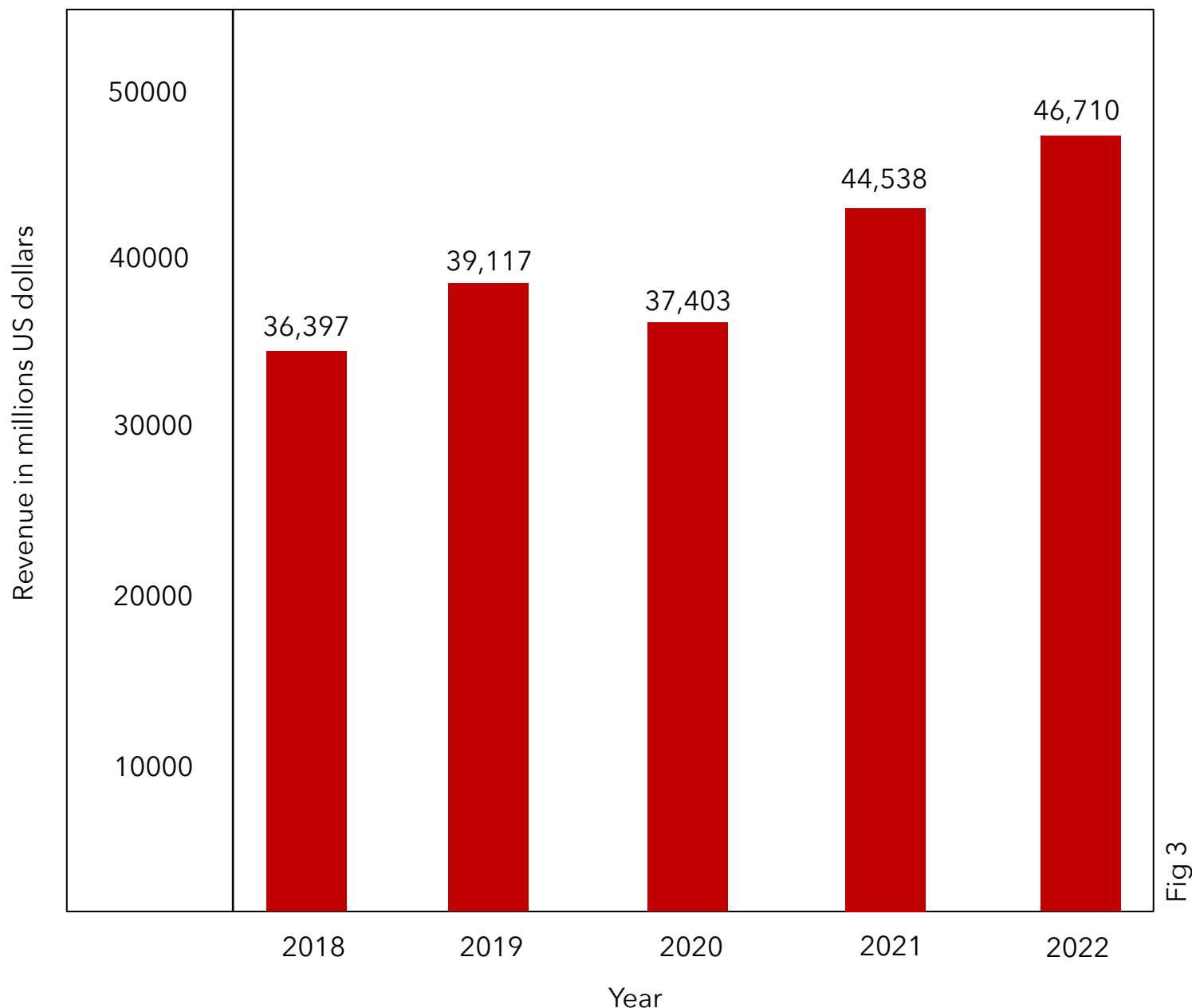

Nike's strong marketing campaigns have been a major factor in its success. One of the essential elements of a successful marketing strategy is the ability to appeal to emotions (Jurek, 2022) by addressing social issues.

When it comes to comprehending and establishing a connection with its customers, Nike has never failed. And there is no denying that they are the most popular brand in the Gen Z age, who demand their products to be unique and constantly have a purpose (Rahilly, 2022).

Other distinctive characteristics of Nike includes being proactive, foreseeing trends, foreseeing customer needs, and celebrity endorsements. Through its influencer marketing, athletes serve as inspiration for people, boosting demands. As of 2022, footwear accounted for over 63% of total sales, with apparel accounting for 28.8%. (Coufano, 2023).

# SWOT Analysis

## Strengths

- Consumer engagement
- Subsidiaries (Converse, Jordans. etc.)
- Brand awareness
- Huge customer base
- Sustainability goals
- Low manufacturing cost
- Consumer engagement

## Weaknesses

- Retailers have a strong hold
- Reliance on the US market
- Poor labor conditions in foreign countries
- Unpaid debts

## Opportunities

- Innovation and tech advancements
- Consumer direct strategy
- Breaking of links with retailers
- Athleisure industry
- Asian nations' emerging markets

## Threats

- Uncertain economic conditions
- Increased competitive pressure
- Counterfeit products



Fig 5 (Nike, 2023)

# PESTLE Analysis

## Political

Increasing government backing for domestic manufacturing in developed economies and Political environments in most key economies are stable. On the other hand, trade restrictions brought on by international disputes (Rowland, 2022) appear as a major threat.

## Economic

Economic factors pose major threats to Nike in terms of Increasing labor prices in underdeveloped nations (Coates, 2023), the considerable shrinking in the Chinese economy where a significant revenue is collected. And most importantly the Exorbitant product and material transportation expenses

## Social

Covid has brought about significant shifts in lifestyle which acts as opportunities to the sporting industry (Pandurangi, 2022). Increasing preference for items produced domestically or regionally and adoption of healthy lifestyles is rising.

## Technological

E-commerce is becoming more and more popular, particularly in emerging economies and buyers have a high availability and usage of information technology. The creation of metaverses stand as both a threat and opportunity (Breiter, Siegfried, 2022).

## Legal

Manufacturing is being impacted by rising minimum wages and stricter employment laws are being enforced considering recent events (Coates, 2023). Progressively increasing consumer safeguards is also a key point as people are more focused on what and how the products they consume are being produced (Wang, Hazen, 2016).

## Ecological

Growing public support for recycling of materials, greater customer preference for firms that are sustainable or green and increasing levels of renewable energy are all possible opportunities (Rowland, 2022).

# Consumers

Gen Z the most along with millennials would be the target market for this line, considering the origin of the concept and their purchasing power. The Gen Z generation has made it apparent what they expect from brands. Their purchases are an expression of who they are as a person with values and ideas. They are examining everything, including sustainable production methods, personnel treatment, and eco-friendly programs (Brooks, 2022). Given that Gen Z and millennials see Nike as the most trustworthy fashion brand (Mantor, 2018), this idea might assist enhancing brand awareness and loyalty with a few modifications to Nike's business strategy.

Recent polls indicate that many young adults in the US and the UK live with their parents to minimize expenses and few because they simply couldn't afford to pay rent. This has resulted in Gen Z spending more than usual (Pandurangi, 2022). With generations passing by, it is evident that Gen Z holds the purchasing power which has a huge effect in driving sales and generating revenue with this campaign

Fig 4 (Wallace, 2022)

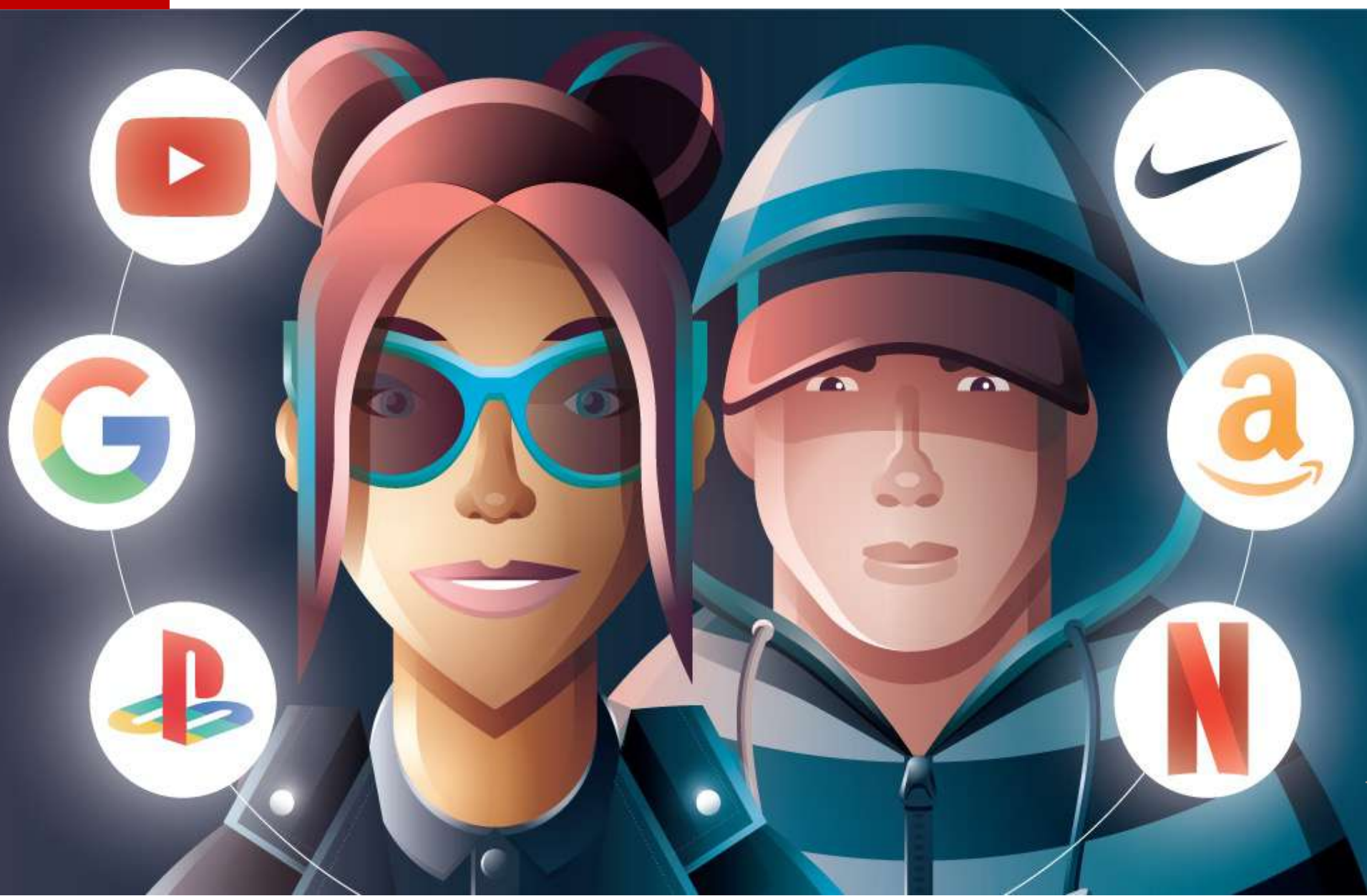

**FILA**



Timberland



Fig 6 (Logos world, n.d)

# Competitor analysis

Nike, like with many other corporations, generated enormous revenues thanks to excessive purchases made after Covid. In the fourth quarter of 2022, Nike's market capitalization was \$12.2 billion (Nike, Inc., 2022). Although Nike stands out with its innovative and robust marketing efforts, it urges to keep up with the other athletic footwear, apparel and equipment companies.

After Adidas and Nike, Puma is the biggest sportswear producer. Puma's serious dedication to sustainability may influence customers to select it over Nike.

In the world of sports wear, Under Armour is a relatively recent addition. Under Armour's growth is mostly driven by North America (Statista, 2022), which is also Nike's largest market.

Nike's current competitors include Adidas, Puma and Under Armour who also specialize in athletic apparel, footwear and accessories. Since the 1980s, Adidas has been its biggest competitor. The recent film "Air," which depicts how the Jordans alliance altered the world of sports and contemporary culture, established that the two businesses compete for market share, endorsement deals, etc.



Fig 7

# Crew Neck T shirt













S. No	Brand	Picture	Retail Selling Price	Fabric Composition	Size	Color	Detail
1.	Nike		£30	100% Cotton (75% organic cotton)	S, M, XL, 2XL, 3XL	White and Black	Loose and soft fit with pocket
2.	Adidas		£33	100% cotton	2XS, XS, S, M, XL, 2XL	Blue and Wonder white	loose-fit crop adidas t-shirt with chest pocket
3.	Puma		£50	74% cotton, 26% polyester (20% recycled material)	XS, S, M, L, XL, 2XL	White, Blue, Yellow	Relaxed fit, Crewneck with chest pocket
4.	Under Armour		£34	100% Polyester (100% recycled fabric)	XS, S, M, L, XL, 2XL	Jet gray, Opal green	Light weight fabric with Secure, zip chest pocket

Fig 8

# Nylon tracks

S. No	Brand	Picture	Retail Selling Price	Fabric Composition	Size	Color	Detail
1.	Nike		£60	60% cotton/37% nylon/3% elastane	XS, S, M, L, XL, 2XL	Fuchsia	Woven soft trousers with stretchy waistband and drawcord
2.	Adidas		£75	100% recycled nylon plain weave	2XS, S, XS, S, M, L, XL	Shadow Red	Loose fit with drawcord on elastic waist
3.	Puma		£65	100% nylon	XS, S, M, L, XL	Royal Sapphire and black	Relaxed fit With Elastic waist with zip closure and cuffs with drawstring
4.	Under Armour		£40	87% Polyester, 13% Elastane	XS, S, M, L, XL, 1X, 2X, 3X	Black and Midnight Navy	Open hand pockets with 2-ply cuffs

# Shorts and T shirt set

S. No	Brand	Picture	Retail Selling Price	Fabric Composition	Size	Color	Detail
1.	Nike		£30	100% cotton (75% organic cotton)	XS, S, M, L, XL, 2XL	Arctic Orange	Extra-oversized fit with Heavyweight cotton fabric
2.	Adidas		£30	70% cotton, 30% hemp single jersey	2X, XS, S, M, L, XL	Clay Strata and Linen Green	Slim fit with ribbed crewneck
3.	Puma		£55	Rib :97% cotton, 3% elastane Shell :68% cotton, 32% polyester (20% organic cotton)	XS, S, M, L, XL, 2T, 3T, 4T	Rose Dust	Ribbed cuffs and waistband with Embroidered PUMA Cat on chest and Logo on left leg
4.	Under Armour		£50	100% nylon	S, M, L, XL, 2XL	Black	Loose fit with logo on the right side of the chest and leg

# Bucket hat





S. No	Brand	Picture	Retail Selling Price	Fabric Composition	Size	Color	Detail
1.	Nike		£25	100% cotton	S, M, L, XL	Orange and Black	soft and sturdy twill fabric with embroidered graphic logo at the centre
2.	Adidas		£23	100% cotton twill	S, M, L, XL	Olive, Quartz, Black and White	Flexible brim with Embroidered Trefoil logo on the front
3.	Puma		£18	100% cotton	S, M, L, XL	Black and White (30% recycled material)	Visor brim with PUMA No. 1 Logo on front And Woven PUMA Cat Logo on side
4.	Under Armour		£40	100% cotton	S, M, L, XL	Black	Sturdy brim with logo print in the center

Fig 11

# Sliders









S. No	Brand	Picture	Retail Selling Price	Fabric Composition	Size	Color	Detail
1.	Nike		£32	NA	3 - 21	mono	Foam cushioning with Padded strap lined with soft fabric
2.	Adidas		£43	NA	3 - 19	14 different styles	Regular fit with textile lining
3.	Puma		£34	NA	6 - 15	Black and White	Padded synthetic strap with Metal PUMA Cat Logo on strap
4.	Under Armour		£17	NA		Black and White	Fixed strap with added foam underneath

Fig 12

# Hoodie with zipper

S. No	Brand	Picture	Retail Selling Price	Fabric Composition	Size	Color	Detail
1.	Nike		£36	80% cotton, 20% polyester with hood lining: 100% cotton.	XS, S, M, L, XL, 2XL	Olive, Black, orchid	Standard fit with Front pockets and Zip-up design
2.	Adidas		£45	53% cotton, 36% recycled polyester, 11% viscose fleece	2XS, XS, S, M, L, XL	Grey and White	Regular fit with full zip and drawcord and adjustable hood
3.	Puma		£42	73% cotton, 27% polyester, Hood Lining: 100% cotton, Shell: 77% cotton, 23% polyester	XS, S, M, L, XL	Black	Regular fit with Full-zip closure
4.	Under Armour		£53	70% Polyester/ 25% Tencel/5% Elastane	XS, S, M, L, XL, 2XL	Orange, Black and Grey	Super-soft, lightweight Terry with stretch material and Open pockets



# Trend analysis

The series is built in accordance with the colour schemes that WGSN predicted will be popular for S/S 2023 through S/S 2025. Post Covid, athleisure is currently seeing a surge as consumers prioritize health and started engaging more in yoga and staying fit. Following the volatility of previous years, often, people seek mental tranquillity (Cording, 2020). The evolution of colour has shifted to more chromatic shades and warm colours creating demand. And remarkably, the trend for pastels, which began early in 2021, has persisted until S/S 2025 with the same saturation levels. (WGSN, 2023).

Soft pastels have been scientifically shown to have calming effects on anxiety, which aligns with the core concept. This could be a huge sales drive attracting young buyers.

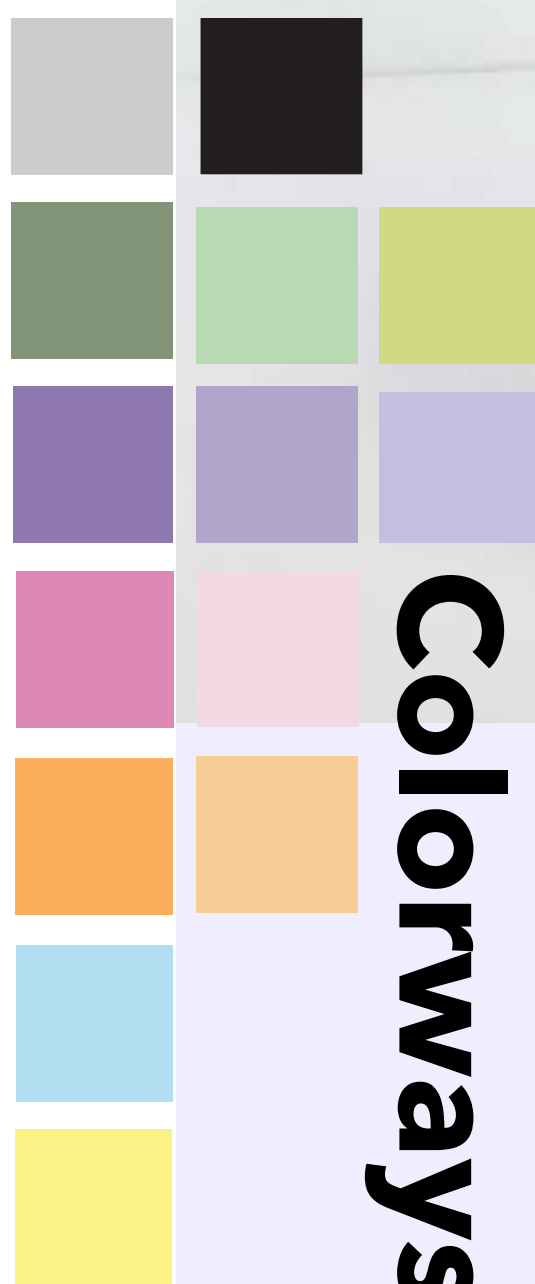

Fig 15 (Asos, 2023)



Fig 16 (Pithers, 2023)



Fig 17 (Leon, 2023)



Fig 18 (Macarol, 2023)



Fig 19 (LaPlaca, 2021)



Fig 20 (Gupta, 2023)



Fig 21 (Hyland, 2022)

Nike boasts a history when it comes to rocking street style, with athletes endorsing and celebrities blending Nike's with their street fashion. The street style and trendy athleisure pieces in this collection are chosen to reflect current market trends. The popular matching pair of shorts and an oversized t-shirt from the epidemic period is said to be the key to generating demand and boosting sales (Hyland, 2022).

Owning a pair of cargos has become universal, being a more versatile pair of trousers having paired right, continues to be popular (Pithers, 2023). A must-have outfit for a "summer kissed vibe" is a neutral or pastel oversized t shirt paired with the cycle shorts hidden at the back of your wardrobe (Gupta, 2022).

Who What Wear, an international fashion brand that curates the hottest celebrity style, runway trends, and shopping advice from the best fashion and beauty experts, was reported as saying that the "'Ugly' Shoe Trend We Can No Longer Ignore" (Who What Wear, 2023). When it comes to footwear, there is a definite trend towards at ease. In the approaching seasons, it is expected to see more items, like clogs and sliders with cushioning and healing capabilities, included into our everyday clothing.

# Final Range Plan S/S 2023



**Crew neck T shirt £30**



**Nylon tracks £64**



**Shorts and Tee set £45**

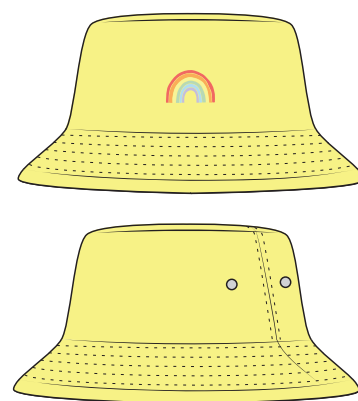

**Bucket hat £25**



**Sliders £34**



**Utilitarian Zip-up Hoodie £65**



Fig 22 (Etsy, n.d)

# Pricing Architecture & Sourcing Strategy

# Pricing Architecture



Fig 23

Although the purpose of this concept revolves around creating awareness and aiding mental health, the concept of making profit is inevitable when it comes to business. It is clear from competitive research that one of Nike's key competitive strategies is its cheap pricing in comparison to Adidas and Under Armour. Being a sports brand holding a history on setting trends, Nike has segregated their pricing based on the target market and regular consumers.

Nike as a brand is appealing to most crowd is because of its capability to be purchased by a wide variety of market consumers.



Fig 24 (Nike, 2023)

For example, products such as the Jordans and Air are fashion yet functional products that are priced high, being trend setters mostly appealing to the younger crowd, the demand for the product is high and hence generates revenue.

Whereas basic products such as the trainers and running shoes which is most prominent in both younger and a slightly senior generation, who exercising walking and indulge in yoga is priced at mid and cheaper levels, making it available to a wider market to increase brand awareness.

Adhering to Nike's hip fashionable athleisure style, this range focuses on creating demand and drive sales by targeting the working-class where most purchase accounts, hence the margin is fixed at 60% for all the products.

The bucket hat, an essential S/S wardrobe equipment, it is priced at £25, serves as the entry product, while the versatile nylon pants which is priced at £64, serves as the exit product.

Saying goodbye to shoes is one of the greatest ways to enjoy the summer. Owing to the Gen Z's preference for distinctive sliders in the summertime aiding to their comfort (Brayshaw, 2023), sliders in different hues depicting the color of flowers appear to be the better product. Matching set being the pandemic era hit (Hyland, 2022) is highly on demand thanks to celebrity street style. The shorts and tee set is priced mid in the range to drive sales due to its demand. Being supplied directly to the charity-Anxiety UK, the utilitarian hoodie is not analyzed with storefronts.

# Sourcing Strategy

The three core administrative concepts that Nike's supply chain revolves around are **outsourcing** to save costs, **diversification** to reduce risk, and **corporate social responsibility** to control the company's effect on the environment in which it operates (Patricia, 2022).

Given the availability of raw materials like cotton and lavender growth for microencapsulation of lavender essential oils to produce scented fabrics, manpower, cheap labor, etc. (with reference to ethics) China would a viable and feasible choice for this range.

China is widely recognized as the world's top producer of cotton, which is a crucial component for this line, followed by India. Despite being second, choosing India may incur transportation costs since it can be quite hard to find the ELS cotton (Chellamani, 2007) needed for hoodies. China ranks as one of the nations with the most advanced machines and methods. Workforce with high skill levels, Chinese employees are renowned for their speed and efficiency while producing high-quality goods, which complements Nike's business strategy of producing a huge volume in a short amount of time (Lopez, 2023).

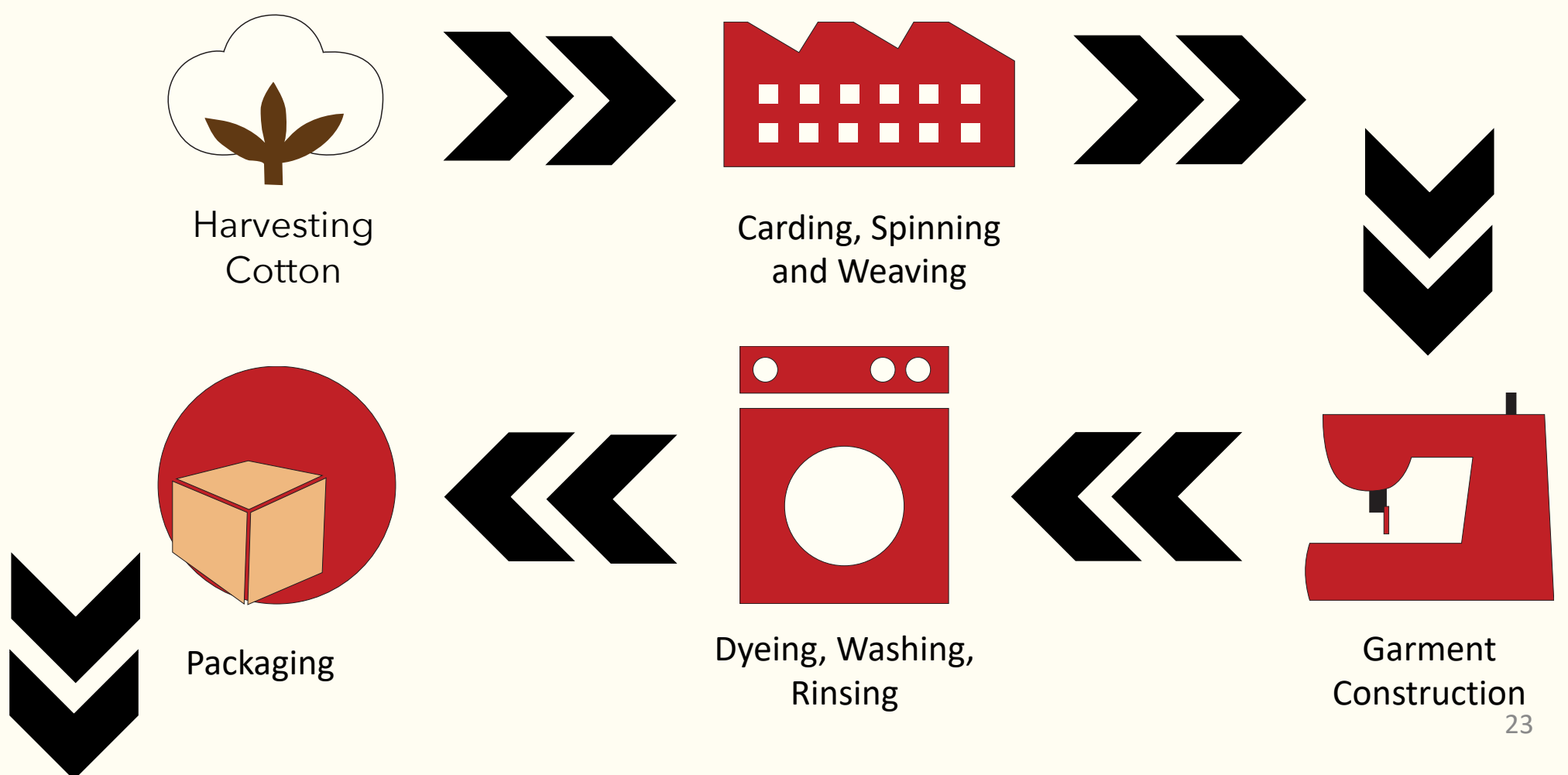



Fig 25 (Created on Illustrator)

However, the necessity of Bluesign certification (Assoune, 2020) and verification by third party Ethical Labor Sourcing Standards from BRE Global (BRE Group, 2022) is imperative given China's past accusations of exploitation of workers and cheap labor costs.

Another major benefit is China's extensive network of manufacturers and suppliers, which significantly lowers transportation costs and, more crucially, carbon emissions. By sourcing and producing in the same country, you can minimize the lead time and speed up production (Jackson and Shaw, 2001).

Nike's factories in China are spread throughout regions like as Guangdong, Jiangsu, Hunan, and Fujian, and are mainly located in industrial parks (Fifield, 2020). The largest shoe manufacturer in the world, Yue Yuen, operates in Hong Kong, China as well. Being one of the key manufacturers, at present China is the house to 112 Nike factories owned and operated by Nike (Pino, 2020), as well as independent contractors.

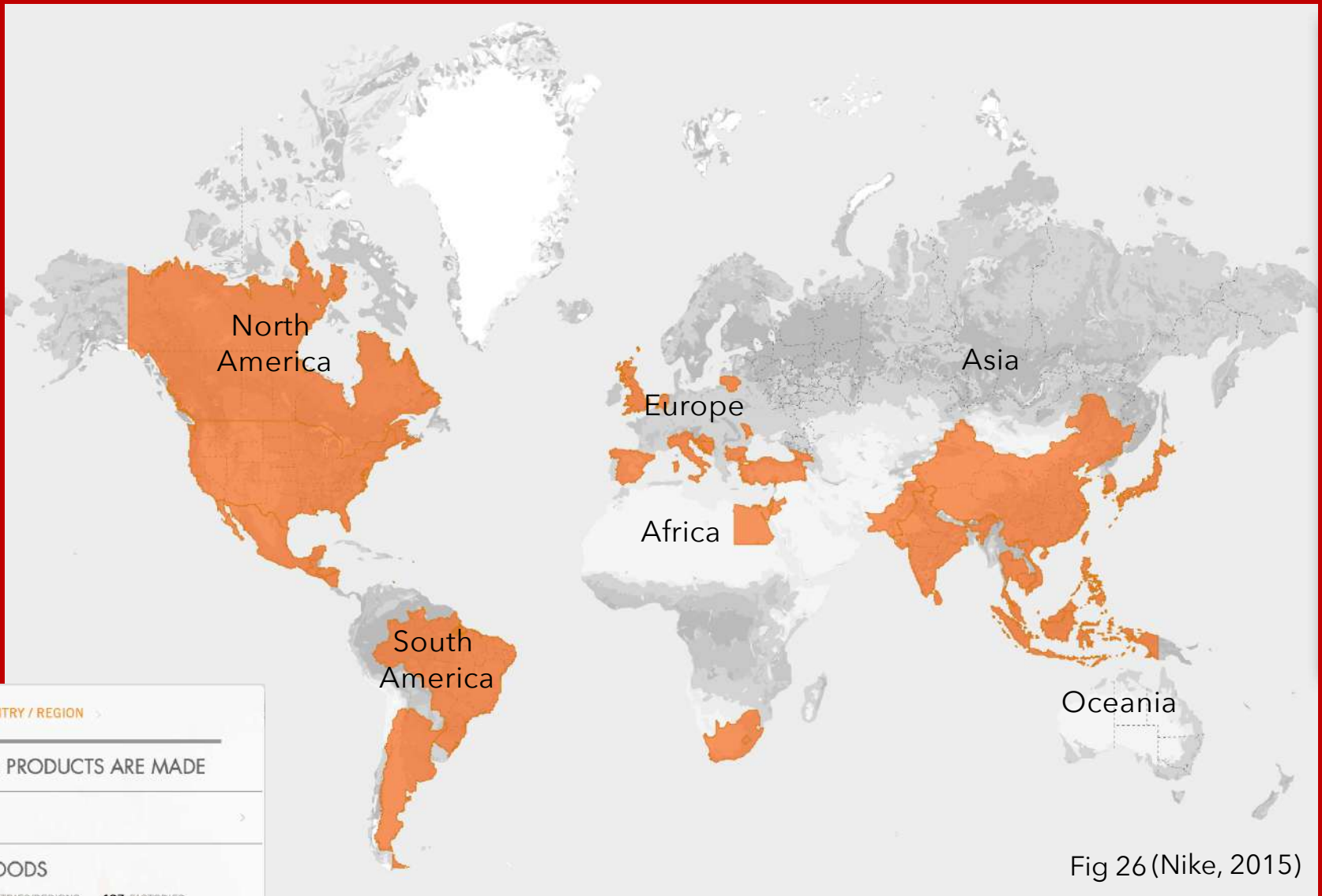

Fig 26 (Nike, 2015)



Fig 27 (Nike, 2015)

In 2015, Nike was among the companies that created a public interactive sourcing website that let users aware of where their goods are being made.



Fig 28 (Nike, 2015)

One of the primary justifications for Nike's cheap costs is the fact that it outsources all of the manufacture of its footwear and garments to third-party suppliers. This sourcing method may be problematic when it comes to quality control (Buia, et al, 2018), for a global corporation recognised for its high standards of quality and creative designs. However, Nike keeps open lines of communication with its suppliers by providing them with the tools and training they need to become familiar with the "Lean Management" framework and Total Quality Management (TQM) a methodology, that ensures quality in every Nike product ever produced (ADEC, 2023).

It might be challenging to determine if each of the 533 factories that produce Nike shoes in 41 nations is ethical, but Nike has accomplished this. When incidences of human trafficking in Malaysia increased in 2019, the business made it a requirement that all prospective workers undergo a thorough identification check, including having their passports scrutinized (Patricia, 2022).

Since collaborating to form the FLA (Fair Labor Association) in 1999 (Nike, 2023), Nike has updated their sourcing strategy to ensure ethical sourcing that is fair to its employees, the environment, and consumers.





Fig 30 (Cightyfourcubecube, n.d)

# Technical Specifications

# NIKE: TECHNICAL SPECIFICATION

Style Description	Crew neck T shirt	Code No	N2001	Branding Labels & Swing tags			
<p>Brand label at the center back, inside the tee 3cm below the neck line stitch</p> <p>Campaign rainbow logo down at 17cm from the shoulder seam and 7cm from the left side seam</p> <p>Washcare tag 3cm above the bottom hem</p> <p>Pocket detail 5cm above the bottom t shirt lining</p> <p>Brand tagline print right aligned to the right seam of the pocket</p>				<p><b>SWING TICKET</b></p> <p><b>Front</b></p> <p><b>Back</b></p> <p><b>Back neck Label</b></p> <p><b>Back view of swing ticket:</b> 3cm width, 1cm height, 1.5cm rainbow logo height, 2cm rainbow logo width.</p>			
Garment Feature	Fabric Composition	Colorways	Brand	Nike	Code No	N2001	
<ul style="list-style-type: none"> <li>- Loose fit crew neck line.</li> <li>- Pocket detail on the right corner with brand detail on it.</li> <li>- Campaign rainbow logo on the top left chest region.</li> </ul>	<ul style="list-style-type: none"> <li>- 100% Cotton, with microencapsulated lavender essential oils.</li> <li>- Weight of the garment 13oz.</li> </ul>	<ul style="list-style-type: none"> <li>■ Pantone 97-9 U</li> <li>■ Pantone 20-2 U</li> <li>■ Pantone 163-13 U</li> <li>□ Pantone 11-0601 TCX</li> </ul>	Season	Spring/Summer	COO	China	
			Size range	S, M, L, XL, 2XL, 3XL			
			Fabric Composition	100% Cotton			
			Technical Designer	Dhaya Sivakumar			

Fig 31

# NIKE: MEASUREMENT SPECIFICATION

## Back neck Label

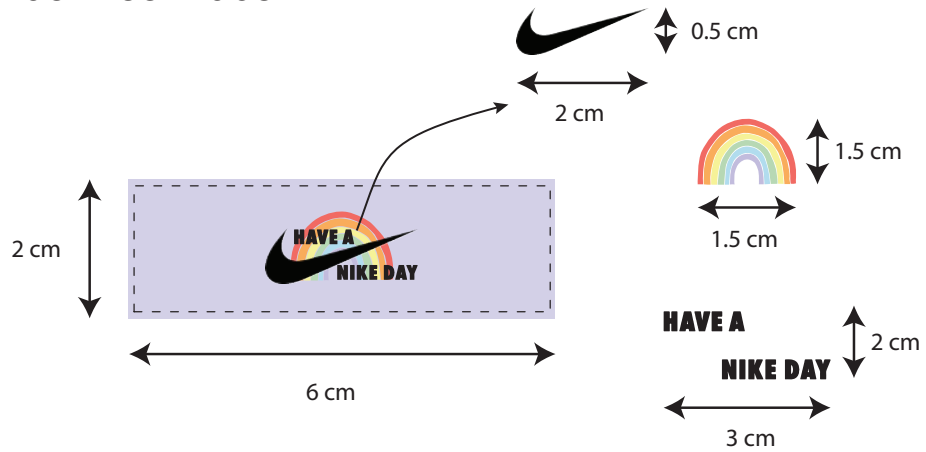

## Washcare Label

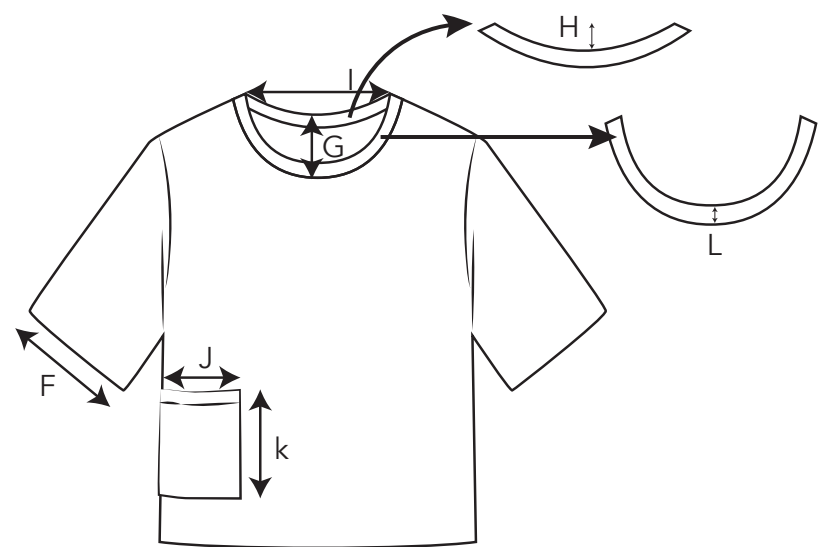
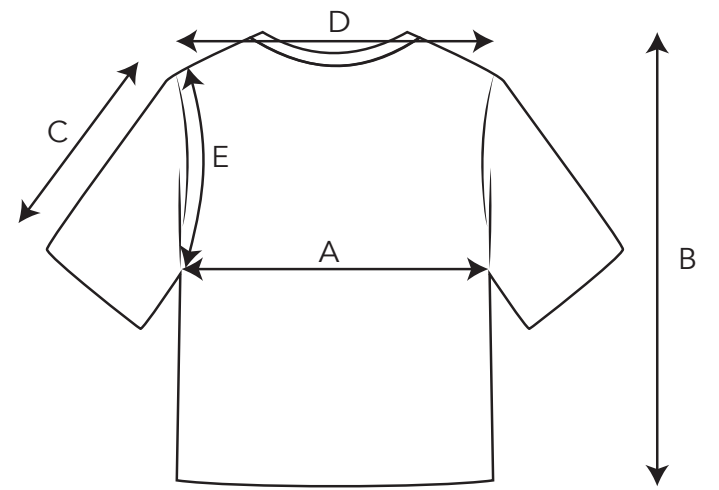
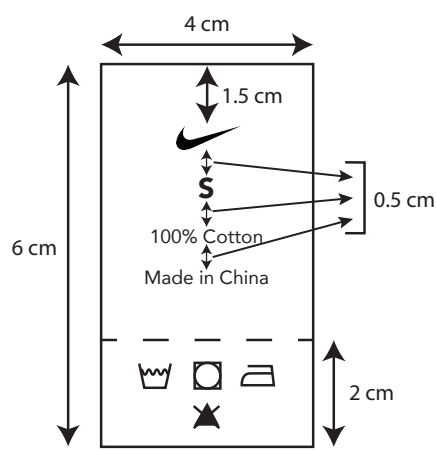

Fig 32

A-Z	Measurements	Centimeters
A	Bust	79
B	Length of body	59
C	Sleeve length from shoulder seam	18
D	Width across shoulder	35
E	Depth of armhole (Shoulder to armhole)	18
F	Sleeve opening (circumference)	10
G	Depth of neck front	10
H	Depth of neck back	3.5
I	Neck width	18
J	Pocket width	9
K	Pocket Length	9.5
L	Neck band width	2

Fig 33

# NIKE: TECHNICAL SPECIFICATION

Style Description	Nylon tracks	Code No	N3001	Branding Labels & Swing tags			
<p>Button faster matching the color of the garment 2cm from centre front and 2cm from the bottom seam of the waistband</p> <p>12cm zipper</p> <p>Washcare tag 2cm from the button at the bottom seam of the waistband</p> <p>Two flap pockets on either sides</p> <p>Fake butt pocket flaps aligning on the back 8cm from the waist band and 3.5cm from centre back</p> <p>Brand label aligned at the center back inside on the waistband with equal distance at the top and bottom</p> <p>Campaign tagline print vertical to the right seam of the pant 5cm from the cargo pockets</p> <p>Belt loops aligning from the center back, with two more 14cm apart</p> <p>Campaign rainbow logo aligned center on the seam of the back left pocket</p> <p>Two belt loops in front 14cm from the center front on either sides</p> <p>Two cargo pockets on either sides at 20cm from the waistband with a flap covering the pocket hole</p> <p>The ends have to be hemmed</p>				<p><b>SWING TICKET</b></p> <p>Front: 4 cm width, 6 cm height. Text: HAVE A NIKE DAY. Nike logo. Dimensions: 4 mm, 1.5 cm, 2 cm, 1 cm, 2.5 cm.</p> <p>Back: 3 cm width, 1 cm height. Text: HAVE A NIKE DAY. Dimensions: 1.5 cm, 2 cm.</p> <p>Brand Label: 4 cm width, 1.5 cm height. Text: HAVE A NIKE DAY.</p> <p>Back of Swing Ticket: Nike logo, S, Nike, Nylon Tracks Code: N3001, Barcode (0 36000 291475 2), 100% Nylon, Made in China, Care symbols.</p>			
Garment Feature	Fabric Composition	Colorways	Brand	Nike	Code No	N3001	
<ul style="list-style-type: none"> <li>- Loose fit nylon tracks.</li> <li>- High waist.</li> <li>- Flap pockets on the right and left side.</li> <li>- Cargo pockets on the right and left side.</li> <li>- Two fake butt pocket flaps on the back.</li> <li>- Campaign tagline print close to the seam on the right leg of the pant.</li> <li>- Campaign logo print on the back left, fake butt pocket.</li> <li>- One button faster with 5 belt loops.</li> </ul>	<ul style="list-style-type: none"> <li>- 100% Nylon</li> </ul>	<ul style="list-style-type: none"> <li>- Pantone 96-12 U</li> <li>- Pantone 177-6 C</li> <li>- Pantone 169-3 U</li> </ul>	Season	Spring/Summer	COO	China	
			Size range	XS, S, M, L, XL, 2XL			
			Fabric Composition	100% Nylon			
			Technical Designer	Dhaya Sivakumar			

Fig 34

# NIKE: MEASUREMENT SPECIFICATION

## Back neck Label

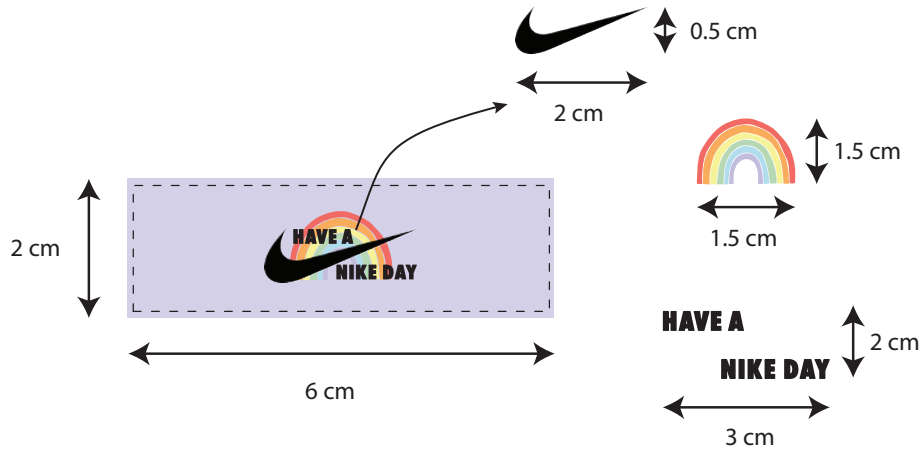

## Washcare Label

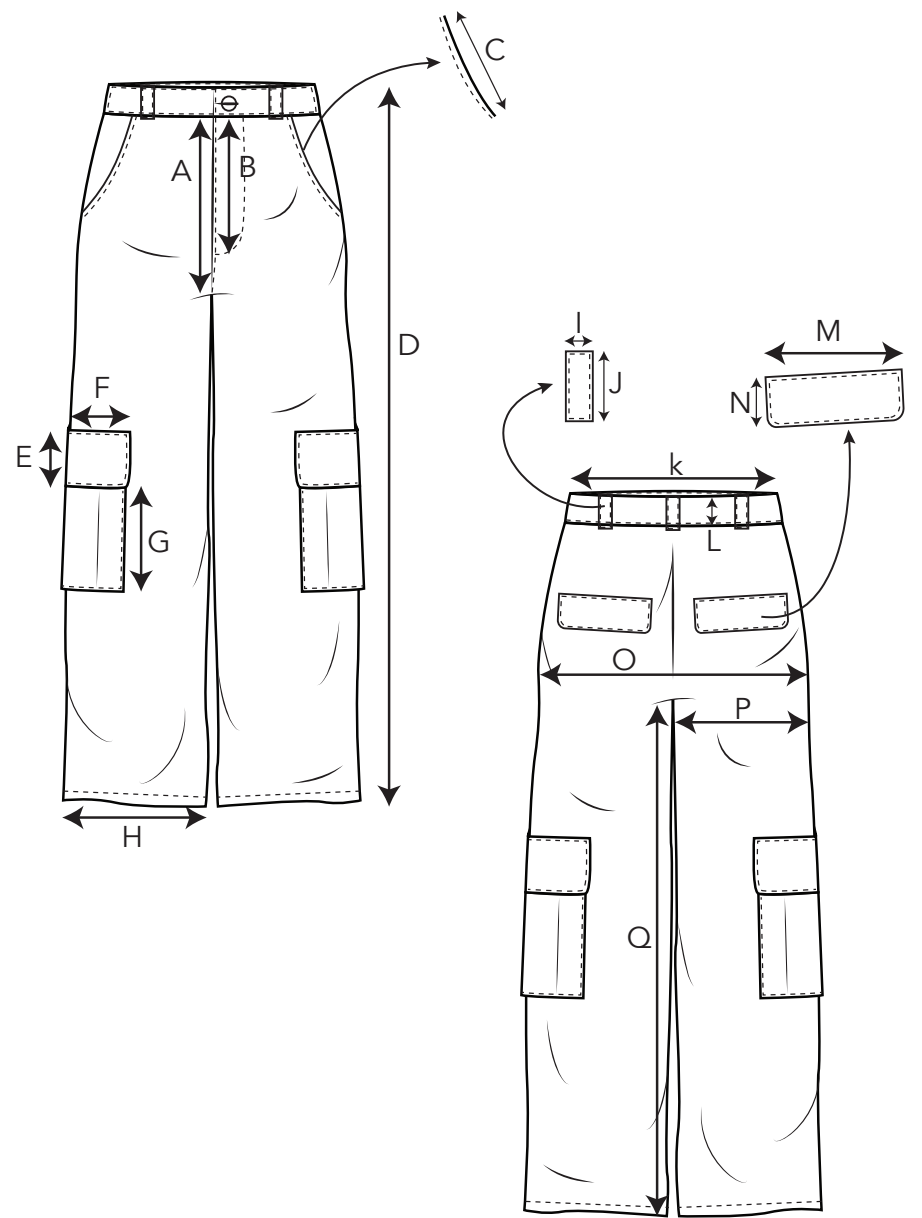
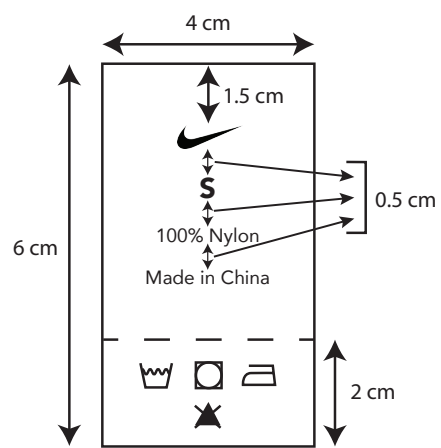

Fig 35

A-Z	Measurements	Centimeters
A	Front rise	9
B	Zipper	12.7
C	Front pocket	14
D	Length of the pant	81
E	Cargo pocket flap width	5
F	Cargo pocket flap length	15
G	Cargo pocket length	19
H	Leg opening	20
I	Belt loop width	1
J	Belt loop height	5
K	Waist	35.5
L	Waist band width	4
M	Back pocket flap length	16
N	Back pocket flap width	6
O	Hip	45.5
P	Thigh	26.5
Q	Inseam	76

Fig 36

# NIKE: TECHNICAL SPECIFICATION

Style Description	Shorts and Tee set	Code No	N4001	Branding Labels & Swing tags			
<p>Crew neck as per measurements</p> <p>Brand back neck label 3cm below back neck seam</p> <p>Dropdown shoulder with 4cm slope</p> <p>Drawstrings respective color as the garment</p> <p>Hem stitch the bottoms</p> <p>Loose fit wide leg as per measurements</p> <p>Campaign rainbow logo on the left chest 22cm from the shoulder seam to 11cm from the arm hole</p> <p>Campaign rainbow letter logo 13cm from back neck seam</p>				<p><b>SWING TICKET</b></p> <p><b>Front</b></p> <p>4 cm</p> <p>4 mm</p> <p>1.5 cm</p> <p>6 cm</p> <p>2 cm</p> <p>1 cm</p> <p>2.5 cm</p> <p>3 cm</p> <p>1 cm</p> <p>2 cm</p> <p>1.5 cm</p> <p><b>Back</b></p> <p>S</p> <p>Nike</p> <p>Shorts and Tee set. Code: N4001</p> <p>100% Cotton</p> <p>Made in China</p> <p><b>Back neck Label</b></p> <p>2 cm</p>			
<b>Garment Feature</b>	<b>Fabric Composition</b>	<b>Colorways</b>	<b>Brand</b>	Nike	<b>Code No</b>	N4001	
<ul style="list-style-type: none"> <li>- Loose fit wide leg shorts and dropdown sleeves.</li> <li>- Brand label inside on the center back of tee and shorts.</li> <li>- Drawstrings with the waist band.</li> <li>- Brand campaign logo in top left of the t shirt.</li> </ul>	<ul style="list-style-type: none"> <li>- 100% Cotton</li> <li>- Weight of the garment 13oz.</li> </ul>	<ul style="list-style-type: none"> <li>■ Pantone 6 C</li> <li>■ Pantone 20-6 U</li> <li>■ Pantone 76-4 U</li> </ul>	<b>Season</b>	Spring/Summer	<b>COO</b>	China	
			<b>Size range</b>	XS, S, M, L, XL, 2XL			
			<b>Fabric Composition</b>	100% Cotton			
			<b>Technical Designer</b>	Dhaya Sivakumar			

Fig 37

# NIKE: MEASUREMENT SPECIFICATION

## Back neck Label

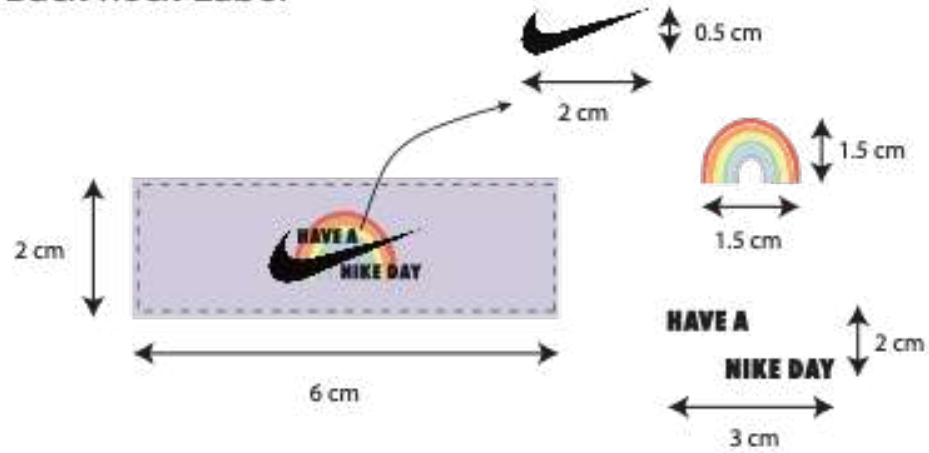

## Washcare Label

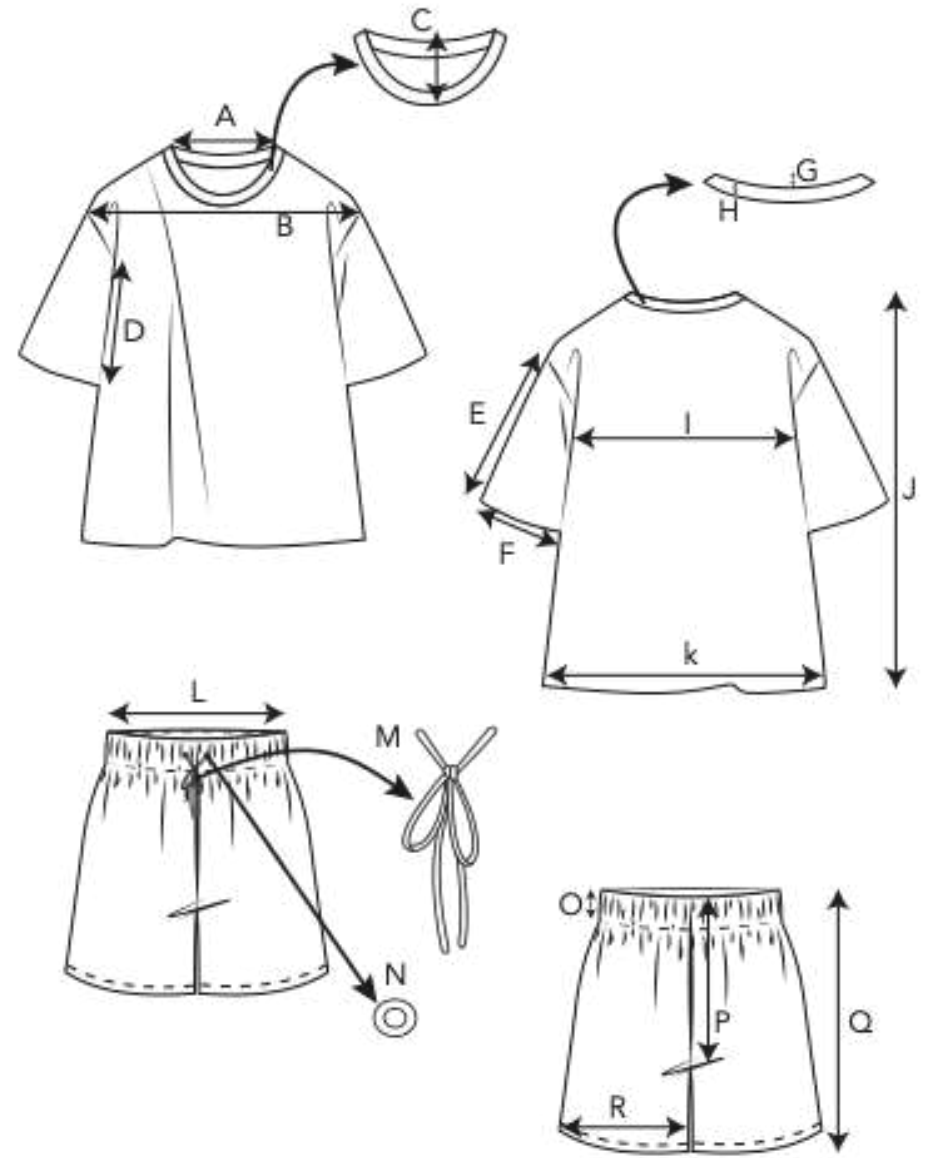
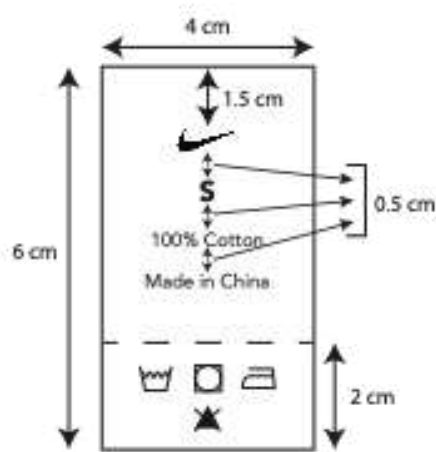

Fig 38

A-Z	Measurements	Measurements
A	Neck width	18
B	Width across shoulder	35
C	Front neck depth	10
D	Armhole length	18
E	Sleeve length (shoulder to seam)	18
F	Sleeve opening	11
G	Back neck depth	3.5
H	Neck band width	1.5
I	Bust	79
J	Body length	60
K	T shirt bottom width	79
L	Waist	74
M	Drawstring length	100
N	Drawstring loop	1x1
O	Waistband width	4
P	Front rise	24
Q	Shorts length	48
R	Leg opening	25

Fig 39

# NIKE: TECHNICAL SPECIFICATION



Style Description	Bucket hat	Code No	N5001	Branding Labels & Swing tags			
 <p>Campaign rainbow logo at 4cm from the top</p> <p>Circular stitch detail with equal distance leaving 1cm seam at the bottom</p> <p>Sweat flap inside the top brim seam of the hat</p> <p>Two air holes 3cm away on either sides of the left seam</p> <p>Brand label inside the centre back at the beginning of the flap stitch</p>				<p><b>SWING TICKET</b></p>  <p>Front: 4 cm width, 6 cm height. Logo 'HAVE A NIKE DAY' with Nike swoosh. Dimensions: 4 mm hole, 1.5 cm top, 2 cm bottom, 2.5 cm width, 1 cm right margin.</p> <p>Back: Size 'S', Nike logo, 'Bucket hat Code: N5001', barcode (0 36000 291475 2).</p> <p>Brand Label: Nike swoosh, 'S', '100% Cotton twill', 'Made in China', care symbols.</p> <p>Brand Label (flap): Nike swoosh, 'HAVE A NIKE DAY', rainbow logo. Dimensions: 2 cm width, 1.5 cm height.</p>			
Garment Feature	Fabric Composition	Colorways	Brand	Nike	Code No	N5001	
<ul style="list-style-type: none"> <li>- Brand campaign rainbow logo aligned in the centre front of the hat.</li> <li>- 5 circular stitches with equal distance starting from the flap of the hat till the end with mentioned space allowance.</li> <li>- Hem is required at the end of the flap.</li> <li>- Two air wholes on either sides of the left seam with equal distance.</li> </ul>	<ul style="list-style-type: none"> <li>- 100% Cotton twill</li> </ul>	<ul style="list-style-type: none"> <li>- Pantone 1- 6 U</li> </ul>	Season	Spring/Summer	COO	China	
			Size range	S, M, L			
			Fabric Composition	100% Cotton			
			Technical Designer	Dhaya Sivakumar			

Fig 40

# NIKE: MEASUREMENT SPECIFICATION

## Back neck Label

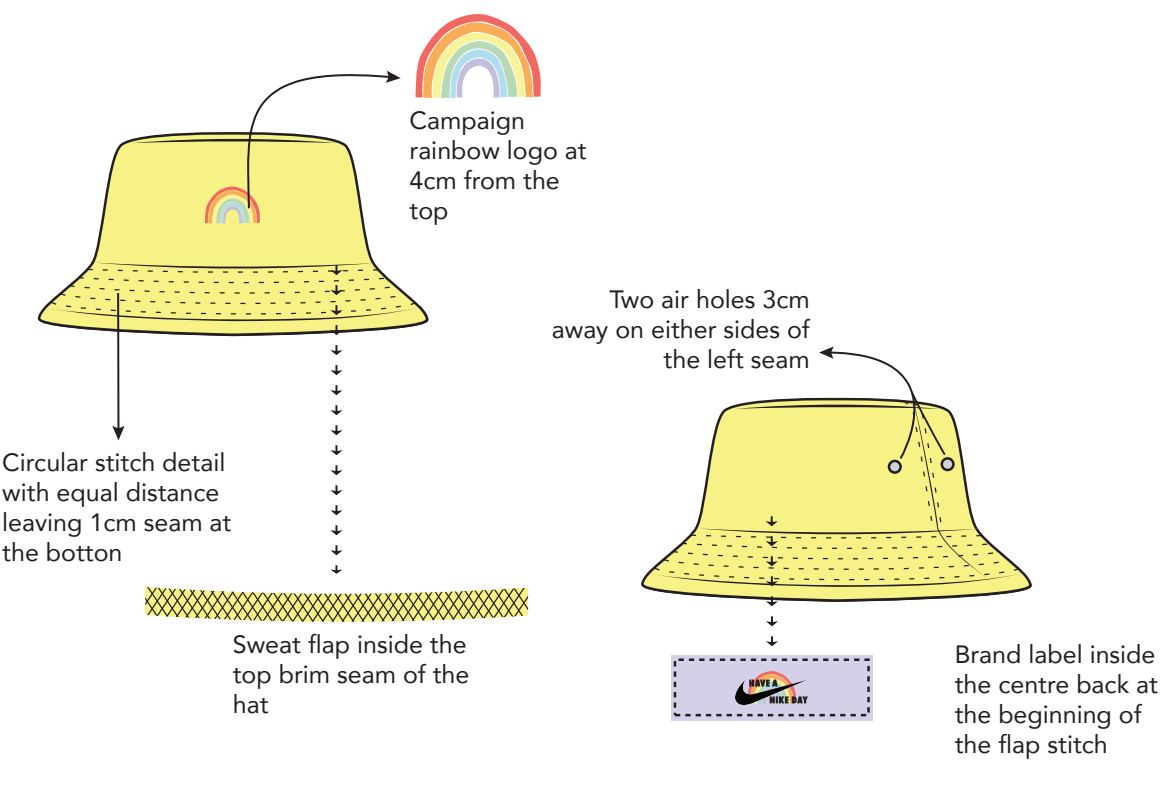

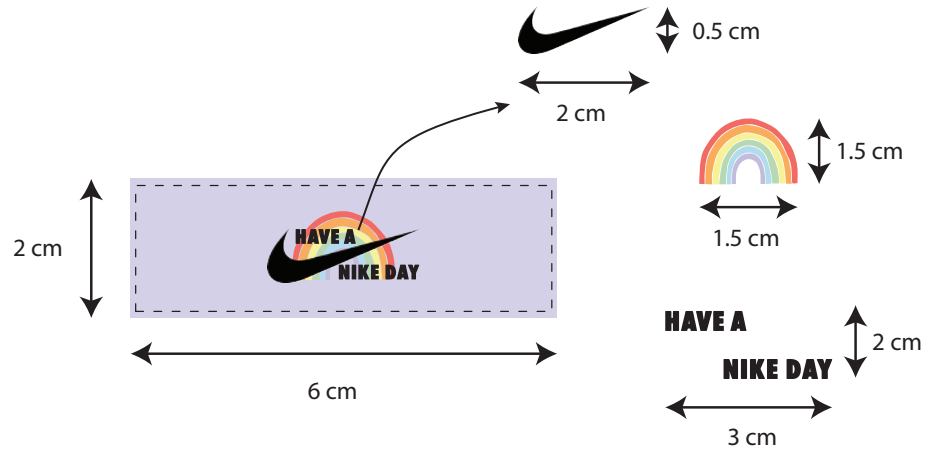
## Washcare Label

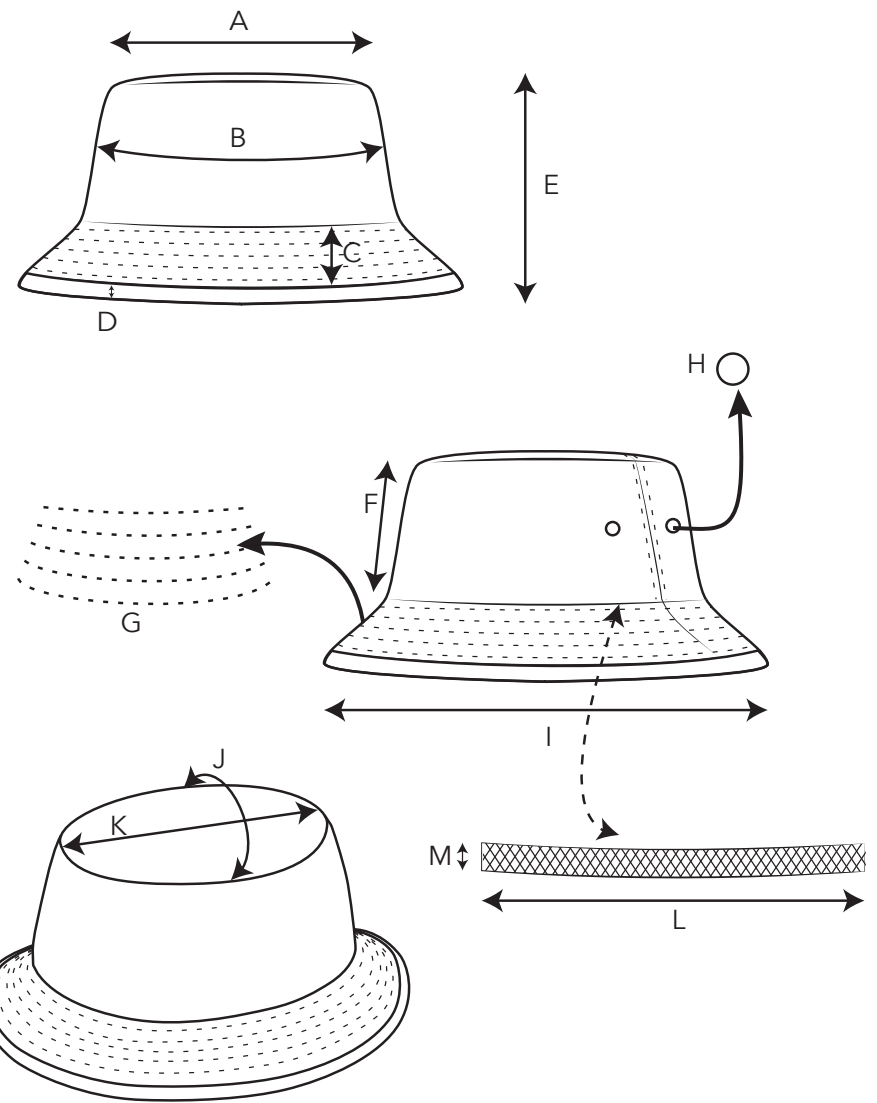
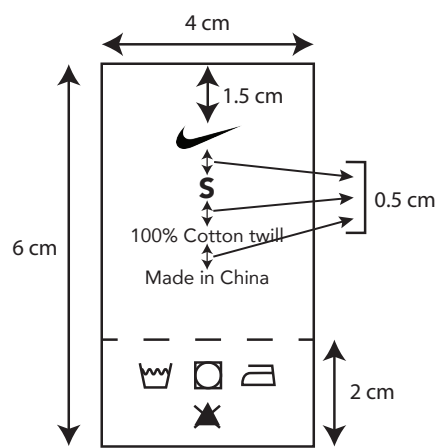

Fig 41

A-Z	Measurements	Centimeters
A	Width	15
B	Head size	60
C	Brim height	6
D	Brim tip	1
E	Hat height	15
F	Crown height	8
G	Circular stitch distance	1
H	Air hole	1x1
I	Hat brim width	17.5
J	Hat top (side to side)	14
K	Hat top (top to bottom)	15
L	Flap length inside the hat	14.5
M	Flap width inside the hat	1.5

Fig 42

# NIKE: TECHNICAL SPECIFICATION

Style Description	Sliders	Code No	N6001	Branding Labels & Swing tags				
				<p><b>SWING TICKET</b></p>				
Garment Feature	Fabric Composition	Colorways	Brand	Nike	Code No	N6001		
<ul style="list-style-type: none"> <li>- Brand campaign logo on the left and right footwear.</li> <li>- Brand logo on the sole of left and right footwear.</li> <li>- A light slope in the toe area of both the footwear.</li> <li>- Ridges at the bottom of the footwear.</li> </ul>	<ul style="list-style-type: none"> <li>- Synthetic leather straps</li> <li>- EVA foam for the sole requiring 1.5 cm thickness</li> </ul>	<ul style="list-style-type: none"> <li>- Pantone 76 -1 U</li> <li>- Pantone 116 -1 U</li> <li>- Pantone 152 -3 U</li> </ul>	Season	Spring/Summer	COO	China		
			Size range		3, 4, 5, 6, 7, 8, 9, 10, 11, 12, 13, 14, 15, 16, 17, 18, 19, 20, 21			
			Fabric Composition		Synthetic leather straps with foam soles			
			Technical Designer		Dhaya Sivakumar			

Fig 43

# NIKE: MEASUREMENT SPECIFICATION

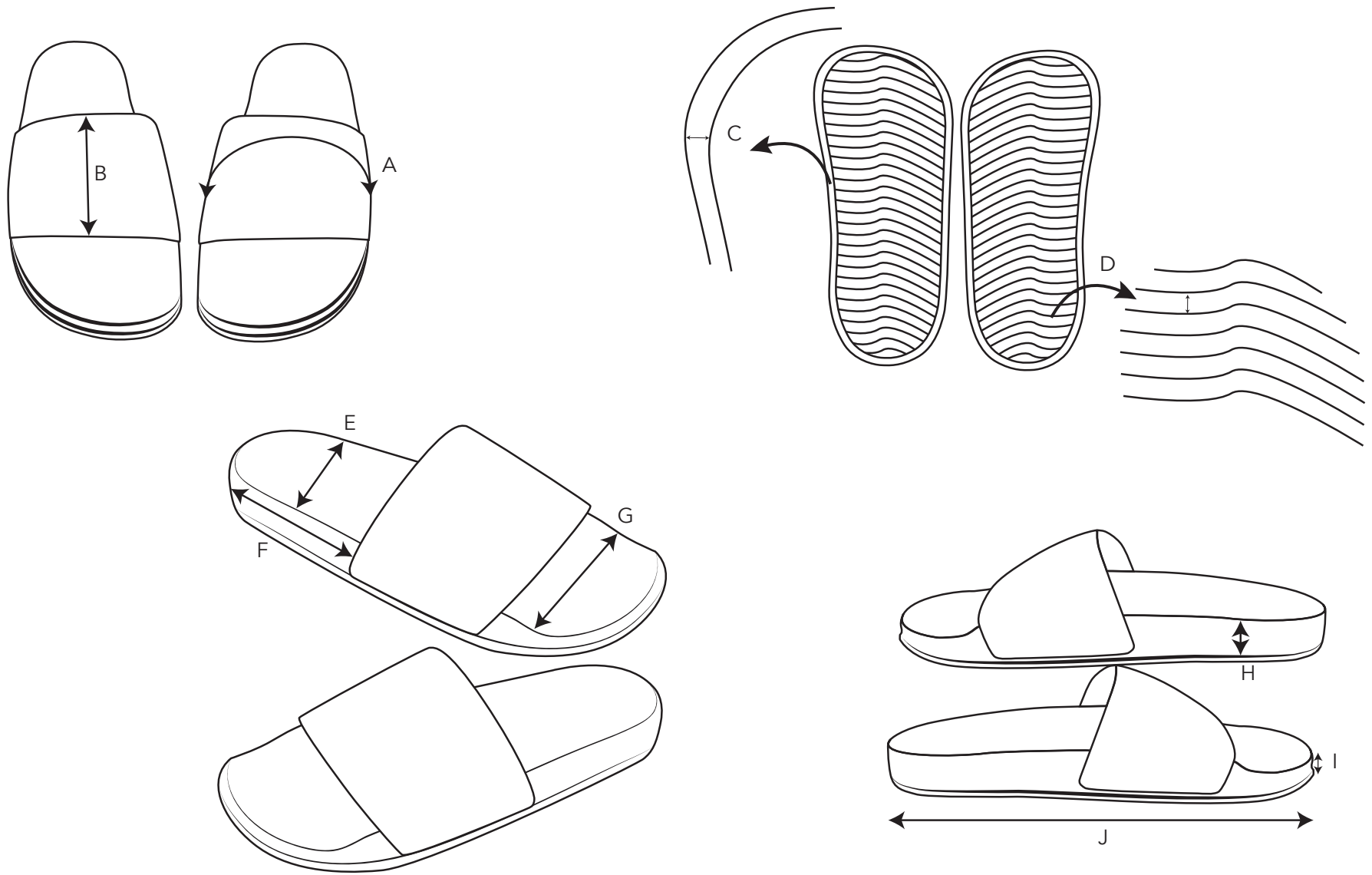

Fig 44

A-Z	Measurements	Centimeters
A	Flap width	15.5
B	Flap length	7.5
C	Outline ridge space under the slide	1
D	Ridge spacing under the slide	1
E	Heel width	7.5
F	Flap placing from the heel	11
G	Forefoot width	9.5
H	Heel thickness	1.5
I	Forefoot thickness	1
J	Slide length (size 5)	24

Fig 45

# NIKE: TECHNICAL SPECIFICATION

Style Description	Zip up Utilitarian Hoodie	Code No	N7001	Branding Labels & Swing tags				
				<p><b>SWING TICKET</b></p> <div style="display: flex; justify-content: space-around;"> <div style="text-align: center;"> <p>Front</p> </div> <div style="text-align: center;"> <p>Back</p> </div> <div style="text-align: center;"> <p>Back neck Label</p> </div> </div>				
Garment Feature	<ul style="list-style-type: none"> <li>- Microencapsulated ELS cotton with lavender essential oils.</li> <li>- Zipper at centre front.</li> <li>- Ribbed cuff and waist.</li> <li>- Pocket insoles sewed with fur swatch.</li> <li>- Brand campaign logo and tagline on the pockets.</li> <li>- Brand logo on the chest.</li> <li>- Words of affirmation rainbow print close to the zipper seam as per measurements.</li> </ul>		Fabric Composition	<ul style="list-style-type: none"> <li>- 100% ELS Cotton, with microencapsulated lavender essential oils.</li> <li>- Synthetic sherpa fur</li> </ul>		Colorways	<ul style="list-style-type: none"> <li>■ Pantone 116- 1 U</li> <li>■ Pantone 100- 2 U</li> </ul>	
Brand	Nike	Code No	N7001	Season	Spring/Summer	COO	China	
Size range		S, M, L, XL, 2XL, 3XL						
Fabric Composition		100% ELS Cotton						
Technical Designer		Dhaya Sivakumar						

Fig 46

# NIKE: MEASUREMENT SPECIFICATION

## Back neck Label

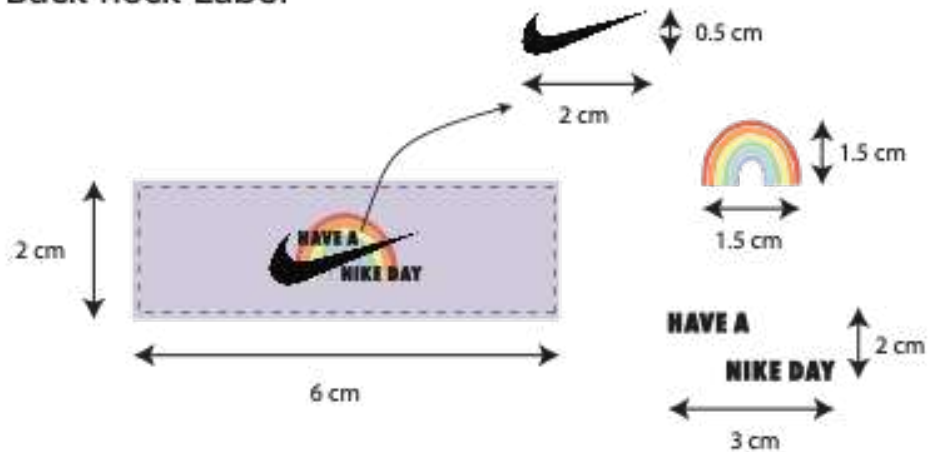

## Washcare Label

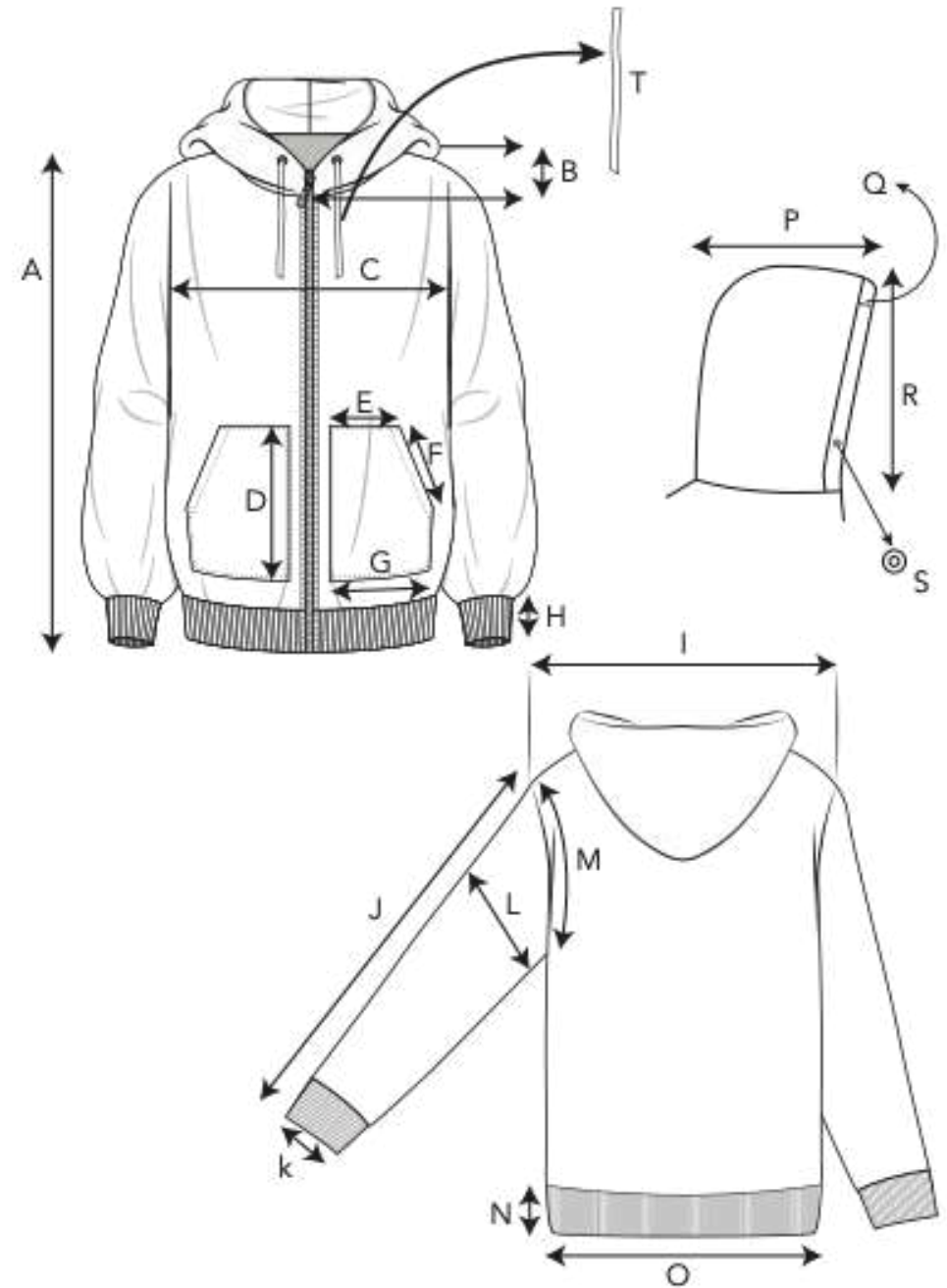
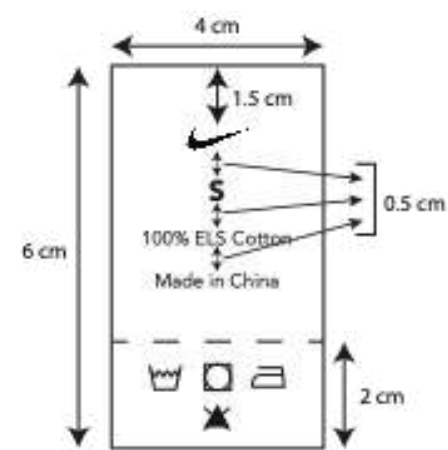

Fig 47

A-Z	Measurements	Centimeters
A	Total length of the hoodie	62
B	Front neck drop	9
C	Bust	79
D	Pocket length	15
E	Pocket top width	10.5
F	Pocket slope length	13
G	Pocket bottom width	8
H	Cuff rib height	6.5
I	Shoulder to shoulder	35
J	Arm length	56
K	Cuff rib width	8
L	Muscle	17
M	Armhole	18
N	Bottom rib height	16.5
O	Bottom width	79
P	Hood width	34.5
Q	Seam width	2.5
R	Hood height	18
S	Drawstring loop	1.5x1.5
T	Drawstring length	38

Fig 48



Fig 49 (Maxim, n.d)

# Product Costing

# Crew neck T shirt

The price of raw material are derived from the offer provided by Chinese suppliers including the labels, polybags and swing tags. Given that it is cheaper compared to air travel, the goods are transported via waterways in accordance with BDCM (Bulk Distribution Carton Metric) dimension guidelines. The exchange rate was set on the day costing was carried out, and duty and clearance is computed using rates provided by the government of UK.

Style: Crew neck T shirt	Code: N2001, N2002, N2003, N2004	Retail Price: £30	Margin 60%
Material	Consumption/ Qty	Unit price	Cost per piece
Cotton fabric	1m	2	2
Thread	50 yards	1.2024 (per 200-yard spool)	1.02
Screen printing	2	0.024	0.05
Labels	2	0.01	0.02
Polybags	1	0.028	0.03
Swing Tags	2	0.039	0.08
<b>Total Component Cost</b>			<b>3.20</b>
Labor (20%)			1.28
Overheads (30%)			1.92
<b>Total Unit Cost Price</b>			<b>6.40</b>
Freight			0.75
ROE (\$1.24/£1) <small>(Price locked on the 27<sup>th</sup> of April)</small>			1.24
D&C (12%)			0.12
<b>Landed Cost Price</b>			<b>£0.69</b>

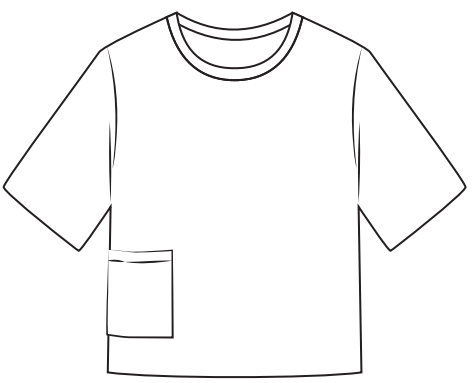
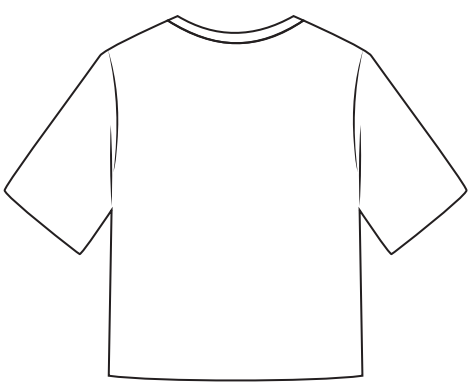



<b>Total Cost</b>	<b>£0.69</b>
<b>Margin</b>	97.69%
<b>Selling Price</b>	<b>£30</b>

Fig 50

# Nylon tracks

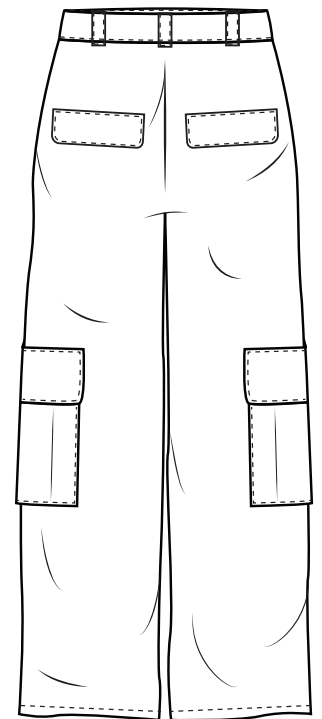
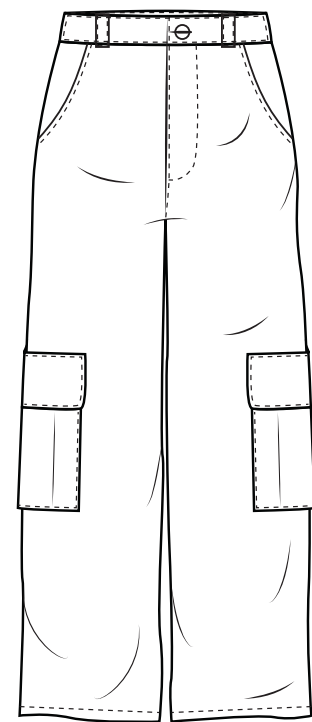
Style: Nylon tracks	Code: N3001, N3002, N3003	Retail Price: £64	Margin 60%
Material	Consumption/ Qty	Unit price	Cost per piece
Cotton fabric	1.5m	0.86	1.29
Thread	197 yards	1.2024 (per 200-yard spool)	1.20
Button	1	0.04	0.04
Zipper	1	0.08	0.08
Screen printing	2	0.024	0.05
Labels	2	0.01	0.02
Polybags	1	0.028	0.03
Swing Tags	2	0.039	0.08
<b>Total Component Cost</b>			<b>2.79</b>
Labor (20%)			1.11
Overheads (30%)			1.67
<b>Total Unit Cost Price</b>			<b>5.57</b>
Freight			0.75
ROE (\$1.24/£1) <small>(Price locked on the 27<sup>th</sup> of April)</small>			1.24
D&C (12%)			0.12
<b>Landed Cost Price</b>			<b>£0.61</b>



<b>Total Cost</b>	<b>£0.61</b>
<b>Margin</b>	99.04%
<b>Selling Price</b>	<b>£64</b>

Fig 51

# Shorts and Tee set

Style: Shorts and Tee set	Code: N4001, N4002, N4003	Retail Price: £45	Margin 60%
Material	Consumption/ Qty	Unit price	Cost per piece
Cotton fabric	1.5m	2	2
Thread	148 yards	1.2024 (per 200-yard spool)	1.18
Drawstring	1m	0.06 (per yard)	0.06
Screen printing	2	0.024	0.05
Labels	2	0.01	0.02
Polybags	1	0.028	0.03
Swing Tags	2	0.039	0.08
<b>Total Component Cost</b>			<b>4.42</b>
Labor (20%)			1.77
Overheads (30%)			2.65
<b>Total Unit Cost Price</b>			<b>8.84</b>
Freight			0.75
ROE (\$1.24/£1) <small>(Price locked on the 27<sup>th</sup> of April)</small>			1.24
D&C (12%)			0.12
<b>Landed Cost Price</b>			<b>£0.93</b>

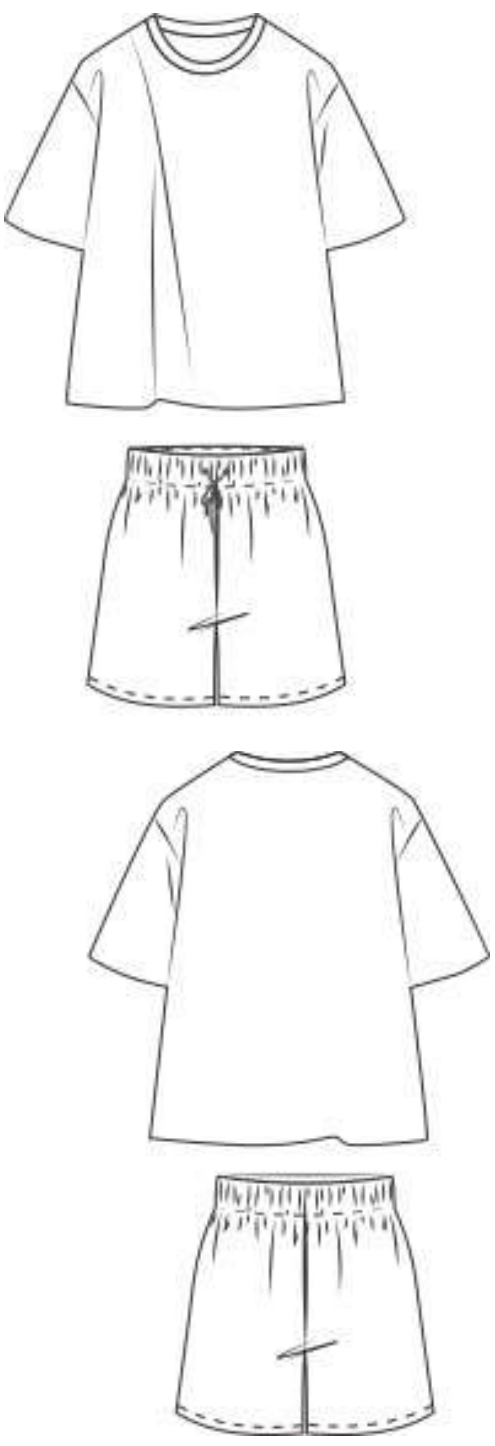

<b>Total Cost</b>	<b>£0.93</b>
<b>Margin</b>	97.94%
<b>Selling Price</b>	<b>£45</b>

Fig 52

# Utilitarian Zip-up Hoodie Tee

Style: Utilitarian Zip-up Hoodie	Code: N7001, N7002, N7003, N7004	Retail Price: £64	Margin 60%
Material	Consumption/ Qty	Unit price	Cost per piece
ELS Cotton fabric	2.2m	2	4.4
Fur	0.64	2.50 (per meter)	1.60
Thread	148	1.2024 (per 200- yard spool)	1.18
Zipper	0.62	0.05 (per 500m roll)	0.03
Drawstring	1m	0.06 (per yard)	0.06
Ribbed knit	1.74	3.50 (per 100m)	0.06
Screen printing	2	0.024	0.05
Labels	2	0.01	0.02
Polybags	1	0.028	0.03
Swing Tags	2	0.039	0.08
<b>Total Component Cost</b>			<b>7.34</b>
Labor 20%			2.94
Overheads 30%			4.41
<b>Total Unit Cost Price</b>			<b>14.69</b>
Freight			0.75
ROE			1.24
D&C			0.12
<b>Landed Cost Price</b>			<b>£1.49</b>



<b>Total Cost</b>	<b>£1.49</b>
<b>Margin</b>	97.67%
<b>Selling Price</b>	<b>£64</b>

Fig 53

# Bucket Hat & Sliders

The bucket hat and the sliders for this collection are sourced from wholesalers in Fujian, China in relatively smaller quantities in order to support Nike's aim to increase demand (Ciment, 2023) in the upcoming years. The price for each slider is \$1.85, while the price for each bucket hat is \$2.

Style: Bucket Hat	Code: N5001	Retail Price: £30	Margin 60%
<b>Total Component Cost</b>			<b>1.85</b>
Labor (20%)			0.74
Overheads (30%)			1.11
<b>Total Unit Cost Price</b>			<b>3.70</b>
Freight			0.75
ROE (\$1.24/£1) <small>(Price locked on the 27<sup>th</sup> of April)</small>			1.24
D&C (12%)			0.12
<b>Landed Cost Price</b>			<b>£0.36</b>

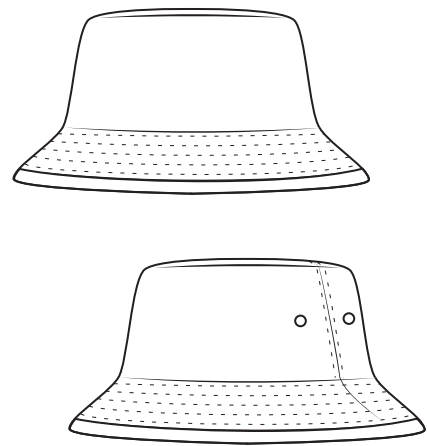

<b>Total Cost</b>	<b>£0.36</b>
<b>Margin</b>	98.95%
<b>Selling Price</b>	<b>£34</b>

Fig 55

Style: Sliders	Code: N6001, N6002, N6003	Retail Price: £30	Margin 60%
<b>Total Component Cost</b>			<b>2.00</b>
Labor (20%)			0.80
Overheads (30%)			1.20
<b>Total Unit Cost Price</b>			<b>4.00</b>
Freight			0.75
ROE (\$1.24/£1) <small>(Price locked on the 27<sup>th</sup> of April)</small>			1.24
D&C (12%)			0.12
<b>Landed Cost Price</b>			<b>£0.39</b>

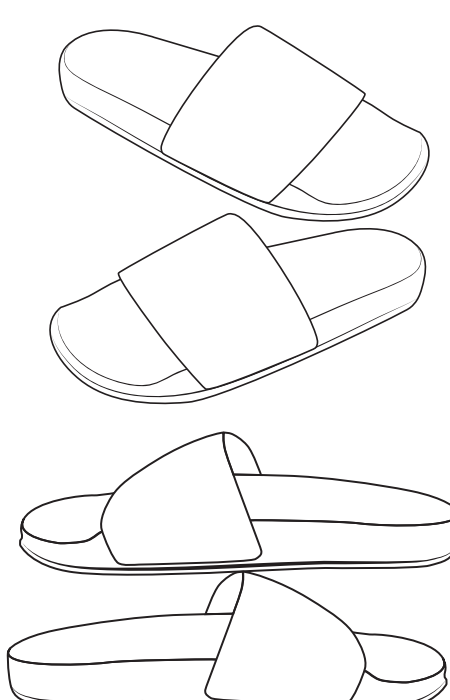

<b>Total Cost</b>	<b>£0.39</b>
<b>Margin</b>	98.45%
<b>Selling Price</b>	<b>£25</b>

Fig 56

# Nike's DTC and Wholesale

After the Pandemic's influence, several fashion businesses had to reconsider their organizational structure. The most frequent were interruptions to the whole supply chains, including those that were connected to manufacturing, supply, and both distribution and sales (Milewska, 2022) since people were mostly homebound.

However, since customers are now actively on the move, novel strategies are required.

Nike's wholesale division rose in Q2 by 30%, according to a study released in December, whereas Nike Direct only had a 25% increase. It is starting to prioritize its wholesale business once again, especially in the midrange channel, as it realizes that its direct business is neither well-positioned to meet the demand nor extremely sustainable (Ciment, 2023).

This additionally has a significant impact on the seasonal sales volumes.



Fig 54 (The Daily Street, 2013)



Fig 57 (Nike, 2023)

# Projected Sales & Promotional Plan

# Sales Budget

Product Name	Picture	Fabric Composition	Season	Colourway	Size Range	RRP (Recommended Retail Price)	CP (Cost Price)	Margin	Quantity	TSV (Total Sales Value)	TCV (Total Cost Value)	Total Profit
Crew neck T shirt		100% Cotton (20% recycled)	Spring/ Summer	Violet, Sand orange, Light green, White	S - 3XL	£30.00	£12.00	60%	3100	£93,000.00	£37,200.00	£55,800.00
Nylon tracks		100% Nylon	Spring/ Summer	Violet, Seaweed green, Grey	XS - 2XL	£64.00	£25.60	60%	5100	£326,400.00	£130,560.00	£195,840.00
Shorts and Tee set		100% Cotton (20% recycled)	Spring/ Summer	Black, Orange, Light blue	XS - 2XL	£45.00	£18.00	60%	5100	£229,500.00	£91,800.00	£137,700.00
Bucket hat		100% Twill cotton	Spring/ Summer	Butter yellow	S - L	£25.00	£10.00	60%	1100	£27,500.00	£11,000.00	£16,500.00
Sliders		Synthetic leather, EVA foam	Spring/ Summer	Pastel pink, Sky blue, Apple Green	Mar-21	£34.00	£13.60	60%	1100	£37,400.00	£14,960.00	£22,440.00
Utilitarian Zip-up Hoodie		100% ELS Cotton (20% recycled)	Spring/ Summer	Sky blue, Lavender	S - 3XL	£65.00	£26.00	60%	100	£6,500.00	£2,600.00	£3,900.00

Fig 58

The goods are sold across England that accounts for 18.8% of the 20% of Gen Z population in the UK (Mintel, 2023).

Particularly in places like London, Birmingham, and Manchester, where there are a combined 11 Nike stores in the UK (Scrapehero, 2023) and where there are also the most student attractions.

Although this holds a risk of generating a slightly lesser revenue considering the restricted availability; Being a limited edition set meeting current fashion needs and Gen Z's must have spring/summer outfits this, also holds a high profitability aspect by creating demand and fashion trends. The availability of essential apparel goods by Nike on wholesale and retail stores, with shoes still being the most revenue generator (Statista, 2022) this might not hinder profits to major extents.

# Sales & Promotional Plan

	Week 1		Week 2		Week 3		Week 4		Week 5		Week 6		Week 7		Week 8	
	9 May - 15 May		16 May - 22 May		23 May - 29 May		30 May - 5 June		6 June - 12 June		13 June - 19 June		20 June - 26 June		27 June - 3 July	
Style	Units Sold	Sales	Units Sold	Sales	Units Sold	Sales	Units Sold	Sales	Units Sold	Sales	Units Sold	Sales	Units Sold	Sales	Units Sold	Sales
<b>Crew Neck T Shirt</b>	500	£15000	500	£15000	400	£12000	400	£12000	400	£12000	300	£9000	100	£3000	100	£3000
<b>Nylon Tracks</b>	750	£48000	750	£48000	700	£44800	700	£44800	700	£44800	650	£41600	425	£27200	425	£27200
<b>Shorts and Tee Set</b>	750	£33750	750	£33750	700	£31500	700	£31500	700	£31500	650	£29250	425	£19125	425	£19125
<b>Bucket Hat</b>	300	£7500	200	£5000	200	£5000	150	£3750	150	£3750	50	£1250	50	£1250	-	-
<b>Sliders</b>	300	£10200	200	£6800	200	£6800	150	£5100	150	£5100	50	£1700	50	£1700	-	-
<b>Utilitarian Zip-up Hoodie</b>	14	£910	14	£910	12	£780	12	£780	12	£780	12	£780	12	£780	12	£780

Fig 59

The expected weekly sales are based on Nike's previous year's results; Europe alone brought in 12.5 million dollars (Statista, 2023), placing it second in terms of revenue. By spreading out the total quantity across 8 weeks with adjustments based on the features of each product's selling rate, the campaign's expected sales are substantially lower given that it only involves 11 locations in England.

For instance, it is anticipated that the crew neck t-shirt would sell a total of 500 pieces in the first week across 11 locations, or around 45 T-shirts every week and 6 per day for each store. With the most student population (Statista, 2022) along with brand recognition of Nike, this is not unattainable in the fashion cities that are recognized for establishing trends.

Regarding the hoodie, an estimate was made based on the prevalence of anxiety in England. Anxiety is often diagnosed in 6 out of a hundred individuals each week (Pindar, 2023). Hence for an eight-week period, an estimate of 100 hoodies is made, assuming 12 pieces per week.

# Size Ratios

Size ratios : Crew Neck T shirt							
Quantity : 3100	S	M	L	XL	2XL	3XL	Total
	1	2	3	3	2	1	12
	8%	17%	25%	25%	17%	8%	100%
	258	518	774	774	518	258	3100

Fig 60

Size ratios :Nylon Tracks							
Quantity : 5100	XS	S	M	L	XL	2XL	Total
	1	2	3	3	2	1	12
	8%	17%	25%	25%	17%	8%	100%
	425	850	1275	1275	850	425	5100

Fig 61

Size ratios :Shorts and Tee Set							
Quantity : 5100	XS	S	M	L	XL	2XL	Total
	1	2	3	3	2	1	12
	8%	17%	25%	25%	17%	8%	100%
	425	850	1275	1275	850	425	5100

Fig 62

Size ratios :Bucket Hat				
Quantity : 1100	S	M	L	Total
	1	2	1	12
	22%	56%	22%	100%
	245	610	245	1100

Fig 63

<b>Size ratios :Sliders</b>				
<b>Quantity : 1100</b>	<b>S</b>	<b>M</b>	<b>L</b>	<b>Total</b>
	1	2	1	12
	22%	56%	22%	100%
	245	610	245	1100

Fig 64

<b>Size ratios : Utilitarian Zip-up Hoodie</b>							
<b>Quantity : 100</b>	<b>S</b>	<b>M</b>	<b>L</b>	<b>XL</b>	<b>2XL</b>	<b>3XL</b>	<b>Total</b>
	1	2	3	3	2	1	12
	8%	18%	24%	24%	18%	8%	100%
	8	18	24	24	18	8	100

Fig 65

# Color Ratios

Color ratios : Crew Neck T shirt								
Size		S	M	L	XL	2XL	3XL	Total
%		8%	17%	25%	25%	17%	8%	100%
Quantity		258	518	774	774	518	258	3100
<b>Violet</b>	<b>40% = 1240</b>	100	210	310	310	210	100	1240
<b>Sand Orange</b>	<b>15% = 465</b>	38	78	116	116	79	38	465
<b>Light Green</b>	<b>15% = 465</b>	38	78	116	116	79	38	465
<b>White</b>	<b>30% = 930</b>	74	158	233	233	158	74	930

Fig 66

Color ratios :Nylon Tracks								
Size		XS	S	M	L	XL	2XL	Total
%		8%	17%	25%	25%	17%	8%	100%
Quantity		425	850	1275	1275	850	425	5100
<b>Violet</b>	<b>34% = 1734</b>	139	297	433	431	295	139	1734
<b>Seaweed Green</b>	<b>33% = 1683</b>	134	286	421	421	186	135	1683
<b>Grey</b>	<b>33% = 1683</b>	134	286	421	421	186	135	1683

Fig 67

Color ratios :Shorts and Tee Set								
Size		XS	S	M	L	XL	2XL	Total
%		8%	17%	25%	25%	17%	8%	100%
Quantity		425	850	1275	1275	850	425	5100
<b>Black</b>	<b>50% = 2550</b>	204	433	638	638	433	204	2550
<b>Orange</b>	<b>20% = 1020</b>	82	173	255	255	173	82	1020
<b>Light Blue</b>	<b>30% = 1530</b>	122	260	383	383	260	122	1530

Fig 68

<b>Color ratios :Sliders</b>					
<b>Size</b>		<b>S</b>	<b>M</b>	<b>L</b>	<b>Total</b>
<b>%</b>		22%	56%	22%	100%
<b>Quantity</b>		245	610	245	1100
<b>Pastel Pink</b>	<b>35% = 385</b>	85	215	85	385
<b>Sky Blue</b>	<b>30% = 330</b>	73	185	72	330
<b>Apple Green</b>	<b>35% = 385</b>	85	215	85	385

Fig 69

<b>Color ratios : Utilitarian Zip-up Hoodie</b>								
<b>Size</b>		<b>S</b>	<b>M</b>	<b>L</b>	<b>XL</b>	<b>2XL</b>	<b>3XL</b>	<b>Total</b>
<b>%</b>		8%	18%	24%	24%	18%	8%	100%
<b>Quantity</b>		8	18	24	24	18	8	100
<b>Sky Blue</b>	<b>50% =50</b>	4	9	12	12	9	4	50
<b>Lavender</b>	<b>50% =50</b>	4	9	12	12	9	4	50

Fig 70

# Critical path

	Week	1	2	3	4	5	6	7	8	9	10	11
	Calendar week	7 <sup>TH</sup> March	9 <sup>TH</sup> March	16 <sup>TH</sup> March	17 <sup>TH</sup> March	22 <sup>nd</sup> March	21 <sup>st</sup> March	26 <sup>TH</sup> March	27 <sup>TH</sup> April	29 <sup>TH</sup> April	6 <sup>TH</sup> May	9 <sup>TH</sup> May
Range Finalization	Concept development meeting											
	Range development											
	Product Finalization for the range											
	Order Confirmation											
	Order Placed											
Manufacturing	Sample from Supplier											
	Garment Fittings											
	Onset of bulk Production											
Product Shipment and Distribution	Quality check											
	Attending to defects											
	Shipment											
	Distribution											
	Launch											

Fig 71

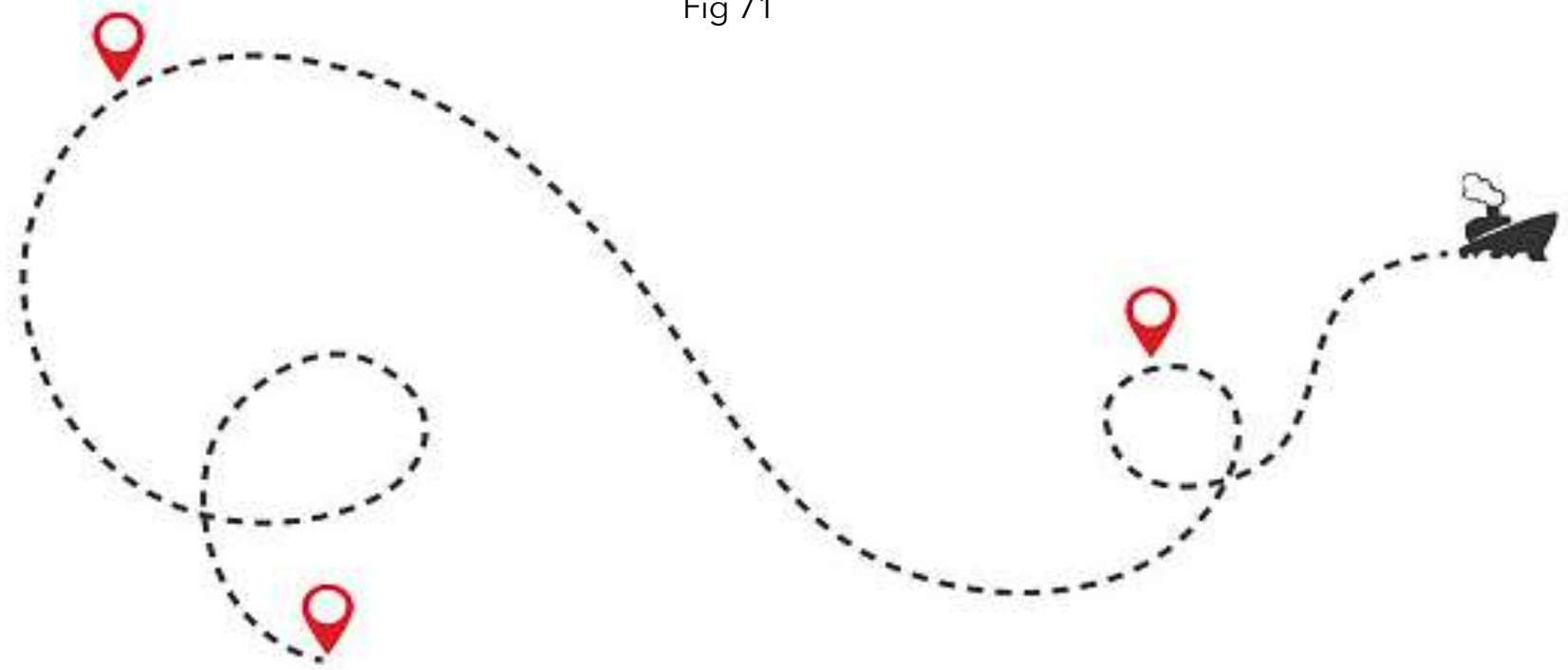



Nike has evolved its corporate structure throughout time to make it more sustainable.

One of the primary explanations for why Nike surpasses its significant competitor adidas is that it employs innovation to build a more sustainable business, to meet competition, and to meet consumer demands. Conversely, Adidas' strong emphasis on innovation, strives to create new goods, services, and procedures to compete (Mahdi et al, 2015).

To accomplish sustainability, this range incorporates the circularity strategy. The circular economy is a type of upcycling that makes sure commodities are not discarded after use and stay if they can in the supply chain (UNEP, 2020).

According to studies, mixed textiles are labor-intensive to sort and considerably harder to recycle. Considering these issues, the entire range is constructed with mono fibers (excluding the trims) for convenient recycling (Beall, 2022).

Another aspect of recycling is converting the garments into pulp and remaking them into fibers. Renewcell, a renowned Swedish textile-to-textile recycling company focuses on synthesizing Circulose and recycling garments. Circulose is a branded dissolving pulp made from 90% cotton-content textile waste that is later transformed into viscose fibers and textiles (Renewcell, 2023).

# Conclusion

The present work explains the justification for a feel-good apparel line for Nike, in line with ideas recognized to help people with anxiety. Although potential drawbacks have been discussed and considered, limitations are unavoidable. However, this line has the chance to be a huge success, helping the brand, customers, and middlemen in the process.

Word count : 3297

# Costing resources

[https://www.made-in-china.com/products-search/hot-china-products/100\\_Cotton\\_Fabric.html](https://www.made-in-china.com/products-search/hot-china-products/100_Cotton_Fabric.html)

[https://www.amazon.com/Sewing-Threads-Colors-Polyester-Machine/dp/B08L38YV9Y/ref=sxin\\_16\\_pa\\_sp\\_search\\_thematic\\_sspa?content-id=amzn1.sym.c8697a08-4071-4b95-a6c6-18057bcdb898%3Aamzn1.sym.c8697a08-4071-4b95-a6c6-18057bcdb898&crd=PNEBRT2NA8AB&cv\\_ct\\_cx=50+yards+per+spool&keywords=50+yards+per+spool&pd\\_rd\\_i=B08L38YV9Y&pd\\_rd\\_r=d3a7aa4c-c1f1-4f33-bbcc-f2bb8b6a5b5d&pd\\_rd\\_w=isuA4&pd\\_rd\\_wg=vOcfg&pf\\_rd\\_p=c8697a08-4071-4b95-a6c6-18057bcdb898&pf\\_rd\\_r=48QEEWFM9VYF85MH79TT&qid=1682446514&sbo=RZvfv%2F%2FHxDF%2BO5021pAnSA%3D%3D&sprefix=50+yards+per+spool%2Caps%2C148&sr=1-1-364cf978-ce2a-480a-9bb0-bdb96faa0f61-spons&pvc=1&spLa=ZW5jcnlwdGVkUXVhbGlmaWVyPUEwMzYwOTE2M1BXUVhXVU1RFRdENyZ3aWRnZXROYW1IPXNwX3NIYXJjaF90aGVtYXRpYyZhY3Rpb249Y2xpY2tSZWRpcmVjdCZkb05vdExvZ0NsaWNrPXRydWU=](https://www.amazon.com/Sewing-Threads-Colors-Polyester-Machine/dp/B08L38YV9Y/ref=sxin_16_pa_sp_search_thematic_sspa?content-id=amzn1.sym.c8697a08-4071-4b95-a6c6-18057bcdb898%3Aamzn1.sym.c8697a08-4071-4b95-a6c6-18057bcdb898&crd=PNEBRT2NA8AB&cv_ct_cx=50+yards+per+spool&keywords=50+yards+per+spool&pd_rd_i=B08L38YV9Y&pd_rd_r=d3a7aa4c-c1f1-4f33-bbcc-f2bb8b6a5b5d&pd_rd_w=isuA4&pd_rd_wg=vOcfg&pf_rd_p=c8697a08-4071-4b95-a6c6-18057bcdb898&pf_rd_r=48QEEWFM9VYF85MH79TT&qid=1682446514&sbo=RZvfv%2F%2FHxDF%2BO5021pAnSA%3D%3D&sprefix=50+yards+per+spool%2Caps%2C148&sr=1-1-364cf978-ce2a-480a-9bb0-bdb96faa0f61-spons&pvc=1&spLa=ZW5jcnlwdGVkUXVhbGlmaWVyPUEwMzYwOTE2M1BXUVhXVU1RFRdENyZ3aWRnZXROYW1IPXNwX3NIYXJjaF90aGVtYXRpYyZhY3Rpb249Y2xpY2tSZWRpcmVjdCZkb05vdExvZ0NsaWNrPXRydWU=)

<https://sanzhuoclothing.en.made-in-china.com/product/HJapNkWPgcVh/China-Custom-Your-Design-Logo-and-Size-High-Quality-Screen-Printing-Custmo-T-Shirt-for-Man.html>

<https://jxartsource.en.made-in-china.com/product/sZwGdOoKxCWT/China-Canvas-Hang-Tag-Fabric-Tag-with-Eyelet-Eco-Friendly-Ink-Printing-Beige-Cotton-Print-Label-Cotton-Custom-Wash-Care-Labels-Garment-Clothing-Accessories.html>

<https://techuangbio.en.made-in-china.com/product/mFDAXUiyEBWk/China-Custom-Plant-Based-Compostable-Courier-Plastic-Envelopes-Tear-Proof-Poly-Mailer-Shipping-Bags.html>

<https://hzfuhan.en.made-in-china.com/product/qySnWLwbMKcY/China-Including-Instruction-Brochure-Brand-Label-Watermark-Price-Swing-Tag.html>

<https://weiweifabric.en.made-in-china.com/product/UZNaRoAvhKpm/China-Waterproof-100-Nylon-Spandex-Soft-and-Crepe-Comfortable-Fabric-Full-Dull-Taffeta-Fabrics-for-Coat-and-Down-Jacket-Garments-of-Ribstop.html>

<https://megatrim.en.made-in-china.com/product/RxfYXCvHgnWK/China-High-Quality-Classic-17mm-Custom-Logo-Denim-Metal-Tack-Jeans-Button-for-Jeans.html>

<https://bagaccessory.en.made-in-china.com/product/nJWRMtfuBEcl/China-3-5-Brass-Yg-Zipper-with-Semi-Auto-Lock-Slider-for-Jeans.html>

<https://phoenixflame.en.made-in-china.com/product/AxMRnglrqCWs/China-Custom-Different-Colorful-Hoodie-Drawstring-Cord-with-Metal-Tips-for-Garment.html>

<https://yuekun.en.made-in-china.com/product/GdXJaWxlOThq/China-Brown-Fake-Fur-Wholesale-Synthetic-Fur-Sherpa-Fur-Animal-Fur.html>

<https://dgpvc21.en.made-in-china.com/product/jwlGDSpyHrfl/China-High-Quality-No-3-and-No-5-PVC-Zipper-Rolls-for-Bags.html>

<https://edwining.en.made-in-china.com/product/WnJpoxmuRzVy/China-Factory-Direct-Custom-Solid-Color-Dyed-Soft-95-Polyester-5-Spandex-Stretch-Hoodie-Rib-Knitted-Fabric-for-Shirting.html>

<https://greenshoechina.en.made-in-china.com/product/AORaIWETmxhp/China-Happy-Slides-Branded-Shoe-Designer-Sandals-Custom-Slides-Custom-Logo-Black-Slides-Sandal-Men-Custom-Printed-Slippers-Slides-Footwear.html>

<https://emande.en.made-in-china.com/product/tmxrzflDophH/China-Twill-Cotton-Bucket-Hat-with-Embroidery-Summer-Fishing-Hat-Outside-Sun-Protective-Casual-Cap-for-Outdoor-Fashion-Cap-Customized.html>

# References

- Admin, J.-. L. (n.d.). *Joe - LMW Admin*. <https://blog.logomyway.com/nike-logo/>
- Affleck, B. (Director). (2023). *Air*. Skydance Sports, Artists Equity, Mandalay Pictures.
- Assoune, A. (2020, September 23). What Does It Mean To Be Bluesign Certified? *Panaprium*. <https://www.panaprium.com/blogs/i/bluesign-certified>
- Bahrani, F. (2011, January 1). *Females Are More Anxious Than Males: a Metacognitive Perspective*. PubMed Central (PMC). <https://www.ncbi.nlm.nih.gov/pmc/articles/PMC3939970/>
- Beall, A. (2022, February 24). Why clothes are so hard to recycle. *BBC Future*. <https://www.bbc.com/future/article/20200710-why-clothes-are-so-hard-to-recycle#:~:text=%E2%80%9CSimilarly%2C%20a%20typical%20pair%20of,using%20a%20range%20of%20dyes.%E2%80%9D&text=This%20makes%20them%20hard%20to%20separate%20so%20they%20can%20be%20effectively%20recycled.>
- Bojamaa, L. (2023). 12 Risky Fashion Trends Of 2023 And How To Pull Them Off. *Glam*. <https://www.glam.com/1196521/risky-fashion-trends-of-2023-and-how-to-pull-them-off/>
- Brayshaw, E. (n.d.). *Gen Z grew up in a world filled with ugly fashion – no wonder they love their Crocs*. The Conversation. <https://theconversation.com/gen-z-grew-up-in-a-world-filled-with-ugly-fashion-no-wonder-they-love-their-crocs-200718>
- BRE Group. (2023, March 14). *BES 6002 – Ethical Labour Sourcing Standard - BRE Group*. BRE Group - Building a Better World Together. <https://bregroup.com/services/standards/ethical-labour-sourcing-standard/>
- Breiter, D. (2022, August 16). *The Metaverse: Exploring Consumer's Expectations, Their Attitudes, and it's Mean-ing to the Fashion Industry*. [https://papers.ssrn.com/sol3/papers.cfm?abstract\\_id=4191523](https://papers.ssrn.com/sol3/papers.cfm?abstract_id=4191523)
- Brooks, R. (2022, August 10). 3 Things You Need To Know About Gen Z And Brand Loyalty. *Forbes*. <https://www.forbes.com/sites/forbesagencycouncil/2022/08/10/3-things-you-need-to-know-about-gen-z-and-brand-loyalty/?sh=1fc4202ec4f2>
- Chellamani, A. B. & D. K. (2007). Present Status and Future Requirement of Extra Long Staple (ELS) Cotton in India. *Fibre2Fashion*. <https://www.fibre2fashion.com/industry-article/1762/present-status-and-future-requirement-of-extra-long-staple-els-cotton-in-india>
- Ciment, S. (2023, March 13). Nike Might Need Wholesale Partners More Than It Thought, Analysts Say. *Footwear News*. <https://footwearnews.com/2023/business/athletic-outdoor/nike-wholesale-channel-dtc-analysts-1203430269/>
- Color Evolution S/S 23*. (2023, April 6). WGSN. <https://www.wgsn.com/fashion/article/641984a04f77b2bc08a44b23#page11>
- Commodity code 6102201000: Overcoats, car coats, capes, cloaks and similar articles - UK Integrated Online Tariff - GOV.UK*. (n.d.). <https://www.trade-tariff.service.gov.uk/commodities/6102201000?country=CN#import>
- Consumer product knowledge and intention to purchase remanufactured products. (2016). *Scinece Direct, Volume 181, Part B*, 10.1016. <https://doi.org/10.1016/j.ijpe.2015.08.031>
- Cording, J. (2020, July 13). How COVID-19 Is Transforming The Fitness Industry. *Forbes*. <https://www.forbes.com/sites/jesscording/2020/07/13/covid-19-transforming-fitness-industry/?sh=2873cb1430a7>
- Cotton production by country worldwide 2021/2022 | Statista*. (2022, August 1). Statista. <https://www.statista.com/statistics/263055/cotton-production-worldwide-by-top-countries/>
- Cuofano, W. I. G. (2023). Nike Business Model: Demand Generation As Core Asset. *FourWeekMBA*. <https://fourweekmba.com/nike-business-model/>
- Dragani, M. (2021). The Fashion Girl's Key to Street Style are These 6 Sneakers - Kylie Jenner Bella Hadid Sne. *L'Officiel USA*. <https://www.lofficielusa.com/fashion/street-style-sneaker-trends-nike-air-jordan-new-balance>
- Eggenberger, M. (2023, March 13). 6 Accessories Trends That Are In for 2023. *Who What Wear UK*. <https://www.whowhatwear.co.uk/accessories-trends-2023/slide24>
- FedEx | System Down*. (n.d.). <https://www.fedex.com/en-gb/online/rating.html#>
- Fifield, A. (2020, March 11). Nike to review supply chains in China after reports Uighurs forced to make shoes. *Washington Post*. [https://www.washingtonpost.com/world/asia\\_pacific/nike-to-review-supply-chains-in-china-after-reports-uighurs-forced-to-make-shoes/2020/03/11/6137df9e-6380-11ea-912d-d98032ec8e25\\_story.html](https://www.washingtonpost.com/world/asia_pacific/nike-to-review-supply-chains-in-china-after-reports-uighurs-forced-to-make-shoes/2020/03/11/6137df9e-6380-11ea-912d-d98032ec8e25_story.html)
- Google Scholar*. (n.d.). [https://scholar.google.com/scholar?hl=en&as\\_sdt=0%2C5&q=jackson+and+shaw+2001+sourcing&btnG=](https://scholar.google.com/scholar?hl=en&as_sdt=0%2C5&q=jackson+and+shaw+2001+sourcing&btnG=)
- Gupta, R. (2023). How To Style Oversized T Shirt | Stylish Tips 2023. *EDRIO*. <https://edrio.com/blogs/blog/style-your-oversized-t-shirt-for-2023>
- Half of UK millennials and Gen Zs feel stressed most of the time*. (n.d.). Deloitte United Kingdom. <https://www2.deloitte.com/uk/en/pages/press-releases/articles/half-of-uk-millennials-and-gen-zs-feel-stressed-most-of-the-time.html>

Hartmans, A. (2022, December 10). Gen Z shoppers are spending big right now, but all those holiday purchases could come back to bite them. *Business Insider*. <https://www.businessinsider.com/gen-z-holiday-spending-using-buy-now-pay-later-bnpl-2022-12?r=US&IR=T>

Hyland, V. (2022, June 16). How the Shorts Set Became the Boss of Summer. *ELLE*. <https://www.elle.com/fashion/a30733264/shorts-set-trend-summer-2022/>

Jackson, T., & Shaw, D. (2001). *Sourcing and Supply Chain Management*. <https://doi.org/10.1007/978>

Jurek, M. (2022, March 3). Why Are Nike Shoes So Darn Popular? - Michele Jurek - Medium. *Medium*. <https://medium.com/@michelejurek16/why-are-nike-shoes-so-darn-popular-fa3b5426730e>

LaPlaca, A. (2021, June 17). Recovery Slides Are the “Ugly” Shoe Trend We Can’t Ignore. *Who What Wear UK*. <https://www.whowhatwear.co.uk/recovery-slides>

Lockwood, L. (2023, January 9). WWD. *WWD*. <https://wwd.com/fashion-news/fashion-scoops/nike-popular-sports-brand-us-rakuten-1235463268/>

Lopez, F. (2023, January 15). Where Are Nike Shoes Made in China? - Shoe Effect. *Shoe Effect*. <https://shoeeffect.com/where-are-nike-shoes-made-in-china/>

Mahdi, H., Abbas, & Mazar, T. (2015). A Comparative Analysis of Strategies and Business Models of Nike, Inc. and Adidas Group with special reference to Competitive Advantage in the context of a Dynamic and Competitive Environment. *Modir*, vol 6(3), 167–177. <http://modir3-3.ir/article-english/isi328.pdf>

Mantor, C. (n.d.). *Nike ranked most trustworthy fashion brand by Gen Z and millennials*. FashionNetwork.com. <https://www.fashionnetwork.com/news/nike-ranked-most-trustworthy-fashion-brand-by-gen-z-and-millennials,996108.html>

*Meet Generation Z: Shaping the future of shopping*. (2020, August 4). McKinsey & Company. <https://www.mckinsey.com/industries/consumer-packaged-goods/our-insights/meet-generation-z-shaping-the-future-of-shopping>

Milewska, B. (2022, February 7). The Impact of the COVID-19 Pandemic on Supply Chains in the Example of Polish Clothing Companies in the Context of Sustainable Development. *Mdpi*. <https://www.mdpi.com/2071-1050/14/3/1899>

Mintel. (2023, March 28). *UK Lifestyles of Generation Z Market Report 2023*. Mintel Store. [https://store.mintel.com/report/uk-lifestyles-of-generation-z-market-report?\\_its=JTdCJTlydmlkJTlyJTJNBjTIyNjc3OGZhNDU0tZGFIMy00N2ViLWI5ZGhM2VjYjM5MWE0YWQyJTlyJTJDJTlyc3RhdGUIMjIIM0EIMjJybhR%2BMTY4MjY5NTEzNn5sYW5kfjJfMzI4M19zZW9fMDA4ZWRhZTJkZTUxMjRiMzRkZTE0NDQxNTM1ZTM5NGYIMjIIN0Q%3D#](https://store.mintel.com/report/uk-lifestyles-of-generation-z-market-report?_its=JTdCJTlydmlkJTlyJTJNBjTIyNjc3OGZhNDU0tZGFIMy00N2ViLWI5ZGhM2VjYjM5MWE0YWQyJTlyJTJDJTlyc3RhdGUIMjIIM0EIMjJybhR%2BMTY4MjY5NTEzNn5sYW5kfjJfMzI4M19zZW9fMDA4ZWRhZTJkZTUxMjRiMzRkZTE0NDQxNTM1ZTM5NGYIMjIIN0Q%3D#)

*National charity helping people with Anxiety - Anxiety UK*. (2023, April 27). Anxiety UK. <https://www.anxietyuk.org.uk/>

*Net revenues of Under Armour worldwide by region, 2021 | Statista*. (2022, May 13). Statista. <https://www.statista.com/statistics/518422/global-net-sales-of-under-armour-by-region/>

Nike. (2015). *Nike Sustainability - Interactive Map*. <https://manufacturingmap.nikeinc.com/#>

*Nike: brand value worldwide 2022 | Statista*. (2022, April 4). Statista. [https://www.statista.com/statistics/632210/nike-brand-value/%20Brand%20Finance.%20\(2022\).%20Brand%20value%20of%20the%20sports%20company%20Nike%20worldwide%20from%202016%20to%202022%20\(in%20million%20U.S.%20dollars\).%20Statista.%20Statista%20Inc..%20Accessed:%20April%2009,%202023.%20https://www-statista-com.mmu.idm.oclc.org/statistics/632210/nike-brand-value/?locale=en](https://www.statista.com/statistics/632210/nike-brand-value/%20Brand%20Finance.%20(2022).%20Brand%20value%20of%20the%20sports%20company%20Nike%20worldwide%20from%202016%20to%202022%20(in%20million%20U.S.%20dollars).%20Statista.%20Statista%20Inc..%20Accessed:%20April%2009,%202023.%20https://www-statista-com.mmu.idm.oclc.org/statistics/632210/nike-brand-value/?locale=en)

*NIKE, Inc. Reports Fiscal 2022 Fourth Quarter and Full Year Results*. (n.d.). <https://investors.nike.com/investors/news-events-and-reports/investor-news/investor-news-details/2022/NIKE-Inc.-Reports-Fiscal-2022-Fourth-Quarter-and-Full-Year-Results/default.aspx>

*Nike’s global revenue, by region 2022 | Statista*. (2022, August 15). Statista. <https://www.statista.com/statistics/241692/nikes-sales-by-region-since-2007/>

*Nike’s North American revenue, by segment 2022 | Statista*. (2022, August 15). Statista. <https://www.statista.com/statistics/241706/nikes-us-sales-by-product-category-since-2007/>

*Our Approach To Sourcing*. (2019, May 2). Nike. <https://about.nike.com/en/newsroom/resources/supplier-relationships>

Patricia. (2022, April 5). *Global Sourcing Nike Case Solution And Analysis, HBR Case Study Solution & Analysis of Harvard Case Studies*. TheCaseSolutions.com. <https://www.thecasesolutions.com/global-sourcing-nike-178305>

Pindar, J. (2023). Anxiety Statistics UK: 2023. *Champion Health*. <https://championhealth.co.uk/insights/anxiety-statistics/>

Pithers, E. (2023, March 31). The 10 Key Spring/Summer 2023 Trends To Know Now. *British Vogue*. <https://www.vogue.co.uk/fashion/gallery/spring-summer-2023-fashion-trends>

*Researchers study anxiety differences between females and males*. (2021, July 7). News. <https://medicine.iu.edu/news/2021/07/researchers-study-anxiety-differences-between-females-and-males>

Rosemary Coates, Executive Director, Reshoring Institute. (2023, January 5). *Global Labor Rates: China is no longer a low-cost country*. Logistics Management. [https://www.logisticsmgmt.com/article/global\\_labor\\_rates\\_china\\_is\\_no\\_longer\\_a\\_low\\_cost\\_country#:~:text=China%20no%20longer%20low%2Dcost&text=Wages%20and%20salaries%20of%20production,labor%20rates%20have%20significantly%20increased](https://www.logisticsmgmt.com/article/global_labor_rates_china_is_no_longer_a_low_cost_country#:~:text=China%20no%20longer%20low%2Dcost&text=Wages%20and%20salaries%20of%20production,labor%20rates%20have%20significantly%20increased)

- Rowland, C. (2022). Nike Inc. PESTEL/PESTLE Analysis & Recommendations. *Panmore Institute*. <https://panmore.com/nike-inc-pestel-pestle-analysis-recommendations>
- Santana, D., & Kish, M. (2023, January 15). Nike is going all in on luxury-obsessed Gen Z. *Business Insider*. <https://www.businessinsider.com/nike-is-targeting-gen-z-china2023-1?r=US&IR=T>
- ScrapeHero. (2023). United Kingdom - March 2023. *ScrapeHero*. <https://www.scrapehero.com/location-reports/Nike-UK/#:~:text=There%20are%2040%20Nike%20retail,as%20of%20March%2024%2C%202023>
- Staff, F. (2023, March 28). Nike. *Fortune*. <https://fortune.com/company/nike/>
- Statista. (2022, February 23). *Universities with the highest number of students in the UK 2020/21*. <https://www.statista.com/statistics/1168605/largest-universities-in-the-uk/>
- The risks and rewards of outsourcing*. (2018, August 10). McKinsey & Company. <https://www.mckinsey.com/industries/metals-and-mining/our-insights/the-risks-and-rewards-of-outsourcing>
- United Nations Environment Programme. (2021). Putting the brakes on fast fashion. *UNEP*. <https://www.unep.org/news-and-stories/story/putting-brakes-fast-fashion>
- Women and mental health*. (n.d.). Mental Health Foundation. <https://www.mentalhealth.org.uk/explore-mental-health/a-z-topics/women-and-mental-health>
- World Health Organization: WHO. (2022). Mental disorders. *www.who.int*. <https://www.who.int/news-room/fact-sheets/detail/mental-disorders>

# Image References

*Before you continue.* (n.d.). [https://www.google.co.in/search?q=fila+logo+png&tbm=isch&ved=2ahUKewj4-YPS-Nj-AhXqkScCHUfCBIIQ2-cCegQIABAA&oq=fila+logo&gs\\_lcp=CgNpbWcQARgBMgcIABCKBRBDMgcIABCKBRBDMgUIABCABDIFCAAQgAQyBQgAEIAEMgUIABCA BDIFCAAQgAQyBQgAEIAEMgUIABCABDIFCAAQgAQ6BAgjECc6BggAEAcQHID0B1jUC2DmGGgAcAB4AIABQ4gBugKSAQE1mAEAoAEB qgELZ3dzLXdpei1pbWfAAQE&sclient=img&ei=sDdSZPjhHuqjnsEPx4SbkAU&bih=792&biw=1570&client=safari&hl=en#imgsrc=QdXF0usBljj41M](https://www.google.co.in/search?q=fila+logo+png&tbm=isch&ved=2ahUKewj4-YPS-Nj-AhXqkScCHUfCBIIQ2-cCegQIABAA&oq=fila+logo&gs_lcp=CgNpbWcQARgBMgcIABCKBRBDMgcIABCKBRBDMgUIABCABDIFCAAQgAQyBQgAEIAEMgUIABCA BDIFCAAQgAQyBQgAEIAEMgUIABCABDIFCAAQgAQ6BAgjECc6BggAEAcQHID0B1jUC2DmGGgAcAB4AIABQ4gBugKSAQE1mAEAoAEB qgELZ3dzLXdpei1pbWfAAQE&sclient=img&ei=sDdSZPjhHuqjnsEPx4SbkAU&bih=792&biw=1570&client=safari&hl=en#imgsrc=QdXF0usBljj41M)

Bojamaa, L. (2023). 12 Risky Fashion Trends Of 2023 And How To Pull Them Off. *Glam*. <https://www.glam.com/1196521/risky-fashion-trends-of-2023-and-how-to-pull-them-off/>

Gupta, R. (2023). How To Style Oversized T Shirt | Stylish Tips 2023. *EDRIO*. <https://edrio.com/blogs/blog/style-your-oversized-t-shirt-for-2023>

Hyland, V. (2022, June 16). How the Shorts Set Became the Boss of Summer. *ELLE*. <https://www.elle.com/fashion/a30733264/shorts-set-trend-summer-2022/>

LaPlaca, A. (2021, June 17). Recovery Slides Are the “Ugly” Shoe Trend We Can’t Ignore. *Who What Wear UK*. <https://www.whowhatwear.co.uk/recovery-slides/slide8>

Macarol, V. (2023, January 10). *Fur bucket hat: fashion trend winter 2023* | *City Magazine*. <https://citymagazine.si/en/fur-bucket-hat-fashion-trend-winter-2023/>

Mclaughlin, A. (2022, March 25). Nike celebrates Air Max Day with larger than life billboard campaign. *Creative Review*. <https://www.creativereview.co.uk/nike-air-max-day-3d-billboard-campaign/>

*Nike Air Force 1 '07 Men's Shoes*. *Nike GB*. (2023, April 14). Nike.com. [https://www.nike.com/gb/t/air-force-1-07-shoes-GjGXSP/CW2288-111?nikegos=true&cp=euns\\_AD\\_PI\\_F3D\\_CMP\\_UK\\_BAU\\_XCT\\_SHOP\\_REV\\_M\\_CW2288-111&cp=47658763634\\_search\\_%7C%7C10628703748%7C110516031008%7C%7Cc%7CEN%7Ccssproducts%7C453317343113\\_GEOZ&ds\\_rl=1252249&gclid=CjwKCAjw0ZiiBhBKEiwA4PT9zyQpQB7BdhAKSIOTVSB6Vo\\_hdcxutOi-jPIpsMXkQ10vXL12YvSgqBoCoNAQAvD\\_BwE&gclsrc=aw.ds](https://www.nike.com/gb/t/air-force-1-07-shoes-GjGXSP/CW2288-111?nikegos=true&cp=euns_AD_PI_F3D_CMP_UK_BAU_XCT_SHOP_REV_M_CW2288-111&cp=47658763634_search_%7C%7C10628703748%7C110516031008%7C%7Cc%7CEN%7Ccssproducts%7C453317343113_GEOZ&ds_rl=1252249&gclid=CjwKCAjw0ZiiBhBKEiwA4PT9zyQpQB7BdhAKSIOTVSB6Vo_hdcxutOi-jPIpsMXkQ10vXL12YvSgqBoCoNAQAvD_BwE&gclsrc=aw.ds)

*Nike Multi Brand Back Graphic T-Shirt*. (n.d.). [Video]. JD Sports. [https://www.jdsports.co.uk/product/red-nike-multi-brand-back-graphic-t-shirt/17234094/?cm\\_mmc=googleshop-\\_google-\\_shopping-\\_pla&istCompanyId=9c5cf6f7-3142-4f9f-be57-2fce9c67adfd&istFeedId=014e8b49-620d-4e56-9e87-79529c403af2&istItemId=rplriamam&istBid=t&gclid=CjwKCAjwxr2iBhBJEiwAdXECw5uk4uXX5p\\_GPxl1f3-1keBmSqYVYQI2p6YzE\\_9RZnDpWJwoHt3t6aBoCOTgQAvD\\_BwE&gclsrc=aw.ds](https://www.jdsports.co.uk/product/red-nike-multi-brand-back-graphic-t-shirt/17234094/?cm_mmc=googleshop-_google-_shopping-_pla&istCompanyId=9c5cf6f7-3142-4f9f-be57-2fce9c67adfd&istFeedId=014e8b49-620d-4e56-9e87-79529c403af2&istItemId=rplriamam&istBid=t&gclid=CjwKCAjwxr2iBhBJEiwAdXECw5uk4uXX5p_GPxl1f3-1keBmSqYVYQI2p6YzE_9RZnDpWJwoHt3t6aBoCOTgQAvD_BwE&gclsrc=aw.ds)

*Nike unisex fleece graphic crew neck sweat in light thistle* | *ASOS*. (n.d.). ASOS. [https://www.asos.com/nike/nike-unisex-fleece-graphic-crew-neck-sweat-in-light-thistle/prd/202965967?currencyid=1&browsecountry=GB&affid=25897&\\_CjwKCAjwjMiiBhA4EiwAZe6jQ701ofGE4mSFLspBFRXWcRkTqiHGqFKG0DfEs1K5cBMk5UkSg3bYxxoC1aAQAvD\\_BwE&channelref=product+search&ppcadref=12029787983%7C117574734673%7Cpla-2003033716314&gclid=CjwKCAjwjMiiBhA4EiwAZe6jQ701ofGE4mSFLspBFRXWcRkTqiHGqFKG0DfEs1K5cBMk5UkSg3bYxxoC1aAQAvD\\_BwE&gclsrc=aw.ds](https://www.asos.com/nike/nike-unisex-fleece-graphic-crew-neck-sweat-in-light-thistle/prd/202965967?currencyid=1&browsecountry=GB&affid=25897&_CjwKCAjwjMiiBhA4EiwAZe6jQ701ofGE4mSFLspBFRXWcRkTqiHGqFKG0DfEs1K5cBMk5UkSg3bYxxoC1aAQAvD_BwE&channelref=product+search&ppcadref=12029787983%7C117574734673%7Cpla-2003033716314&gclid=CjwKCAjwjMiiBhA4EiwAZe6jQ701ofGE4mSFLspBFRXWcRkTqiHGqFKG0DfEs1K5cBMk5UkSg3bYxxoC1aAQAvD_BwE&gclsrc=aw.ds)

*nike (United Kingdom)*. (2023). Nike.com. <https://www.nike.com/gb/>

*Nike's Best Lightweight Running Shoes for Speed and Performance*. (n.d.). Nike.com. <https://www.nike.com/a/most-lightweight-running-shoes>

Pithers, E. (2023, March 31). The 10 Key Spring/Summer 2023 Trends To Know Now. *British Vogue*. <https://www.vogue.co.uk/fashion/gallery/spring-summer-2023-fashion-trends>

*Shoebox Wallpapers - Wallpaper Cave*. (n.d.). <https://www.bvdssej.ga/ProductDetail.aspx?iid=277827171&pr=61.88>

*Sneaker box illustrations by Stephen Cheetham*. (2014, December 5). THE DAILY STREET. <https://www.thedailystreet.co.uk/2013/09/sneaker-box-illustrations-by-stephen-cheetham/>

*Variable Data Management and Printing | Maxim Label and Packaging - maxim*. (n.d.). <https://www.maxim-group.com/products/variable-data/price-tickets.html>

Wallace, B., & Wallace, B. (2022). How Brands are Adapting to Appeal to Gen Z. *WebProNews*. <https://www.webpronews.com/gen-z-brands/>

# Bibliography

- Admin, P. (2022). Best Waterproof Fabrics. *Parentgiving*. <https://www.parentgiving.com/elder-care/best-waterproof-fabrics/>
- Cuofano, W. I. G. (2023). Nike Business Model: Demand Generation As Core Asset. *FourWeekMBA*. <https://fourweekmba.com/nike-business-model/>
- Fibre2Fashion. (2013). Fragranced clothes and cosmetic-textiles. *Fibre2Fashion*. <https://www.fibre2fashion.com/industry-article/7204/fragranced-clothes-and-cosmetic-textiles>
- Gupta, S. (2023). Nike SWOT 2023 | SWOT Analysis of Nike. *Business Strategy Hub*. <https://bstrategyhub.com/swot-analysis-of-nike-nike-swot-analysis/>
- Ho, S. (2022, June 18). Nike Shoes: Where Are They Made? - Hood MWR. *Hood MWR*. <https://www.hoodmwr.com/where-are-nike-shoes-made/>
- Hughes, J. (2023, March 14). Nike Competitors Analysis - Business Chronicler. *Business Chronicler*. <https://businesschronicler.com/competitors/nike-competitors-analysis/>
- Kert, M., Tavcer, P., Hladnik, A., Spasic, K., Puac, N., Petrovic, Z., & Gorjanc, M. (2021). Application of Fragrance Microcapsules onto Cotton Fabric after Treatment with Oxygen and Nitrogen Plasma. *Mdpi, Vol 11(10)*, 1181. <https://doi.org/10.3390/coatings11101181>
- Mateos, G. (2021, December 15). Nike's Pricing strategy withing the extended marketing mix. *Medium*. <https://medium.com/@gemamateos.gmc/nikes-pricing-strategy-withing-the-extended-marketing-mix-52e644f67954>
- Meet Generation Z: Shaping the future of shopping*. (2020, August 4). McKinsey & Company. <https://www.mckinsey.com/industries/consumer-packaged-goods/our-insights/meet-generation-z-shaping-the-future-of-shopping>
- Nike Products Are Manufactured in Over 41 Countries* | *Sourci*. (n.d.). <https://sourci.com.au/blog/nike-products-are-manufactured-in-over-41-countries/>
- Price Pack Architecture - IRI*. (n.d.). <https://www.iriworldwide.com/en-us/insights/publications/price-pack-architecture>
- Pricing structure: Tips, definition, and examples*. (n.d.). <https://www.paddle.com/resources/pricing-structure>
- Priyanka, M. S. a. S. P. (2007). Fragrance Finishing of Textiles. *Fibre2Fashion*. <https://www.fibre2fashion.com/industry-article/1929/fragrance-finishing-of-textiles>
- Schneider, B., & Lee, D. (2022, December 6). BoF Insights | Nike and Gucci Top Gen-Z's Favourite Fashion Brands. *The Business of Fashion*. <https://www.businessoffashion.com/articles/retail/bof-insights-nike-and-gucci-top-gen-zs-favourite-fashion-brands/>
- Weaver, C. (2020, November 2). What in the World Is a \$590 Scratch-and-Sniff T-shirt Doing in 2020? *The New York Times*. <https://www.nytimes.com/2020/11/02/style/scratch-and-sniff-Tshirt-lanvin.html>